

Architectural  
elements

CO  
AV  
R  
O

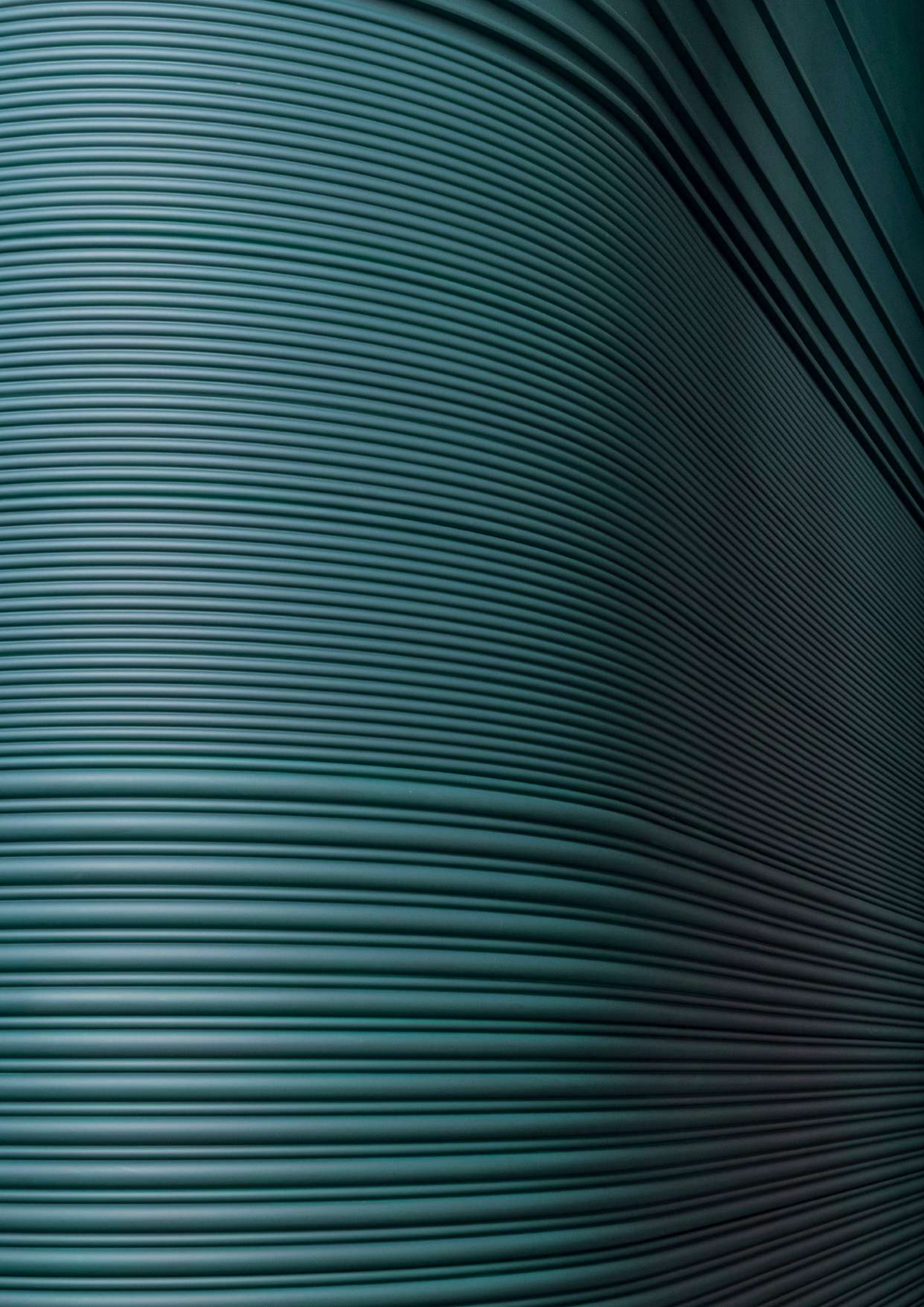



# — A legacy of craftsmanship

1970 marked the birth of a vision. A vision of always innovating, always transforming. Pushing the boundaries of material science. From crafting ornate decor to pioneering technology materials in the industry, to Duropolymer.

From our genesis as Orac to our expansion into Orac Decor, our journey now brings us back to where it all began: Orac, coming full circle.



1970

Start of Ostend Research and Application Company

1980



Focus on decorative ornaments

1992



Introduction of flexible products

2000



Start of extrusion

2002



Second generation management

2010



Solar field and ISO14001 certification

2012



Modern concept

# ORAC

We shed our old skin — Orac Decor —  
to emerge simply as Orac, a name  
that encapsulates our essence and  
our expansive vision for the future.

NL —

1970 betekende de geboorte van een visie. De visie om altijd te innoveren, om altijd te transformeren. Om de grenzen van materiaalwetenschap te verleggen. Sinds meer dan vijftig jaar drijft onze passie voor innovatie ons tot de creatie van sierlijke ornamenten, baanbrekende technologische materialen alsook Duropolymer. We zijn altijd op zoek naar de brug tussen het blijvende en het revolutionaire. Met elk nieuw kalenderjaar hebben wij – bij Orac – onze originele identiteit overstegen. Van ons ontstaan als Orac tot onze uitbreiding naar Orac Decor, brengt onze reis ons nu terug naar waar het allemaal begon: we zijn opnieuw Orac, de cirkel is rond. We zijn meer dan ambachtslieden in decor, we zijn pioniers, visionairs, verhalenvertellers op vlak van interieur.

FR —

1970 a marqué la naissance d'une vision. La vision de toujours innover, de toujours transformer. Repousser les limites de la science des matériaux. Depuis plus de cinquante ans, notre passion pour l'innovation nous a conduits de la fabrication d'ornements décoratifs à la création de matériaux technologiques pionniers dans l'industrie jusqu'au Duropolymer. Nous cherchons toujours à marier le révolutionnaire au durable. À chaque tournant du calendrier, nous – chez Orac – avons transcendé notre origine. De notre genèse en tant qu'Orac à notre expansion en tant qu'Orac Decor, notre voyage nous ramène aujourd'hui là où tout a commencé : Orac, la boucle est bouclée. Nous sommes plus que des artisans de la décoration ; nous sommes des pionniers, des visionnaires, des narrateurs dans le monde de l'intérieur.

DE —

1970 war die Geburtsstunde einer Vision. Einer Vision der ständigen Innovation, des ständigen Wandels. Die Grenzen der Materialwissenschaft zu überschreiten. Seit über fünfzig Jahren treibt uns unsere Leidenschaft für Innovation an – von der Herstellung kunstvoller Dekore bis hin zu bahnbrechenden technologischen Materialien wie Duropolymer. Immer mit dem Bestreben, das Beständige mit dem Revolutionären zu verbinden. Mit jedem Jahr sind wir – bei Orac – über unsere ursprüngliche Identität hinausgewachsen. Von unserer Entstehung als Orac bis zu unserer Expansion zu Orac Decor führt uns unsere Reise nun dorthin zurück, wo alles begann: Orac, womit sich der Kreis schließt. Wir sind mehr als Dekorationshandwerker; wir sind Pioniere, Visionäre, Geschichten-erzähler der Inneneinrichtung.

ES —

1970 marcó el nacimiento de una visión. Una visión de innovar siempre, de transformarse constantemente. Superando los límites de la ciencia de los materiales. Durante más de cincuenta años, nuestra pasión por la innovación nos ha llevado desde la fabricación de elementos decorativos a materiales pioneros en la industria de la tecnología hasta llegar al Duropolymer. Siempre buscando combinar lo perdurable con lo revolucionario. Con cada giro del calendario, en Orac hemos trascendido a nuestra identidad original. Desde nuestra génesis como Orac hasta nuestra expansión a Orac Decor, nuestro viaje nos lleva ahora de Vuelta al punto de partida: Orac, cerrando así el círculo. Somos más que artesanos de la decoración; somos pioneros, visionarios y narradores del interiorismo.

At Orac, we've always believed that there are many sides to a wall, and we are committed to choosing the good one. In a world where design often feels transient, we've chosen a different path.



Sustainability goes beyond the use of recycled materials; it's about designing ideas that stand the test of time. We understand that true sustainability means creating products that remain relevant for generations, not just a few fleeting years.



— A  
commitment  
carved in  
walls

**NL —**

Bij Orac geloven we al sinds jaar en dag dat een muur vele kanten heeft, en wij zetten ons in om steeds de goeie kant te kiezen. In een wereld waar design vaak vluchtig is, bewandelen wij een ander pad. Duurzaamheid reikt verder dan het gebruik van gerecycleerde materialen, het gaat om het creëren van concepten die de tand des tijds doorstaan. We begrijpen dat echte duurzaamheid inhoudt dat we producten maken die generaties lang meegaan, en niet slechts enkele voorbijgaande jaren relevant zijn.

**DE —**

Wir bei Orac haben schon immer daran geglaubt, dass eine Wand viele Seiten hat, und wir haben uns entschieden, die gute Seite zu wählen. In einer Welt, in der sich Design oft vergänglich anfühlt, haben wir einen anderen Weg gewählt. Nachhaltigkeit geht über die Verwendung recycelter Materialien hinaus; es geht darum, Ideen zu entwickeln, die Bestand haben. Wir wissen, dass echte Nachhaltigkeit bedeutet, Produkte zu schaffen, die für Generationen relevant bleiben, nicht nur für ein paar flüchtige Jahre.

**FR —**

Chez Orac, nous pensons qu'un mur peut avoir plusieurs aspects, et nous nous engageons à choisir le meilleur. Dans un monde où le design peut sembler éphémère, nous avons pris une voie différente. Pour nous, la durabilité va au-delà de l'utilisation de matériaux recyclés, c'est trouver des idées de conception qui durent dans le temps. La véritable durabilité signifie créer des produits pertinents pour les générations à venir, et pas seulement pour quelques années.

**ES —**

En Orac siempre hemos creído que una pared tiene muchas caras, y nosotros nos comprometemos a elegir la buena. En un mundo en el que el diseño parece ser efímero, nosotros elegimos perdurar. La sostenibilidad va más allá del uso de materiales reciclados; se trata de diseñar ideas que resistan el paso del tiempo. Entendemos que la verdadera sostenibilidad significa crear productos que sigan siendo relevantes durante generaciones y no unos pocos años.



# — Every wall is a blank canvas



Where others see a flat surface, we see a world of possibilities. A clean primer, waiting for a little intervention. A bare base, in need of shape and dimension. A neutral support, asking to be someone's project and the centre of their attention. Which is all why, at Orac, we like to say we're visual artists of sorts — taking walls as a field of experimentation and at any time, seeking to honour their unique creative potential.

## Foundations

### NL —

Waar anderen niet meer dan een vlakke zien, ontvouwt zich voor ons een horizon vol mogelijkheden. Een ongerept doek, klaar voor een creatieve ingreep. Een lege basis die smacht naar vorm en diepte. Een neutrale wand die uitnodigt om het hart van iemands project te worden. Dat is de reden waarom we bij Orac onszelf beschouwen als beeldhouwers van de ruimte – we omarmen muren als ons atelier voor experiment en ontdekking, altijd op zoek om hun unieke creatieve essentie tot uiting te laten komen.

### FR —

Là où d'autres voient une surface plane, nous voyons un monde de possibilités. Un socle impeccable, qui attend une petite intervention. Une base vierge, qui a besoin d'une forme et d'une dimension. Un support neutre, qui demande à être le projet de quelqu'un et le centre de son attention. C'est pourquoi, chez Orac, nous aimons dire que nous sommes des sortes d'artistes visuels, considérant les murs comme un champ d'expérimentation et cherchant à tout moment à honorer leur potentiel créatif unique.

### DE —

Wo andere eine flache Oberfläche sehen, sehen wir eine Welt voller Möglichkeiten. Eine makellose Grundlage, die auf einen kleinen Eingriff wartet. Eine blanke Basis, der es an Form und Dimension mangelt. Eine neutrale Fläche, die darauf wartet, das Projekt von jemandem zu sein und im Mittelpunkt der Aufmerksamkeit zu stehen. Aus diesem Grund bezeichnen wir uns bei Orac als eine Art visuelle Künstler, die Wände als Experimentierfeld nutzen und stets versuchen, ihr einzigartiges kreatives Potenzial zu entfalten.

### ES —

Donde otros ven una superficie plana, nosotros vemos un mundo de posibilidades. Una superficie limpia, a la espera de una pequeña transformación. Una base neutra que necesita forma y dimensión. Un lienzo en blanco, que pide ser el proyecto de alguien y el centro de su atención. Por eso, en Orac nos gusta decir que somos como artistas visuales, que consideramos las paredes como campo de experimentación y tratamos en todo momento de honrar su potencial creativo único.





Whether it's a touch of the contemporary or a nod to the classics, each of our products is a chameleon, adept at taking on the character you desire. Here are some glimpses into the myriad of ways our products can animate, define and transform interiors.

Every setting, every angle reveals new potential. A new story to be told.

# Unexpected possibilities

NL –

Of het nu een moderne flair is of een knipoog naar het klassieke, onze producten zijn net kameleons die naadloos samenvloeien met hun omgeving en toch een uniek karakter behouden. Laat u inspireren door de subtiele kunst van verfijning en ontdek hoe de kleinste aanraking een ruimte kan omtoveren tot een canvas van persoonlijke expressie. Met Orac aan je zijde is elke ruimte een uitnodiging om te dromen, te ontwerpen en te inspireren.

FR –

Des possibilités inattendues. Qu'il s'agisse d'une touche contemporaine ou d'un clin d'œil aux classiques, chacun de nos produits est un caméléon, capable de prendre le caractère que vous souhaitez. Nous aimons vous donner un aperçu de la myriade de façons dont nos produits peuvent agrémenter, définir et transformer les espaces. Chaque décor, chaque angle révèle un nouveau potentiel. Une nouvelle histoire à raconter.

DE –

Unerwartete Möglichkeiten. Ob mit einem Hauch von Modernität oder einer Anspielung auf die Klassiker: Jedes unserer Produkte ist ein Chamäleon, das den von Ihnen gewünschten Charakter annehmen kann. Wir geben Ihnen gerne einen Einblick in die unzähligen Möglichkeiten, wie unsere Produkte animieren können, Räume zu definieren und zu transformieren. Jede Umgebung, jeder Blickwinkel, eröffnet neue Möglichkeiten. Eine neue Geschichte, die erzählt werden muss.

ES –

Posibilidades inesperadas. Ya se trate de un toque contemporáneo o de un guiño a los clásicos, cada uno de nuestros productos es un camaleón, capaz de adoptar el carácter que se le quiera dar. Aquí hay algunos ejemplos de las innumerables formas en que nuestros productos pueden animar, definir y transformar espacios. Cada escenario, cada ángulo revela un nuevo potencial. Una nueva historia que contar.

# Content

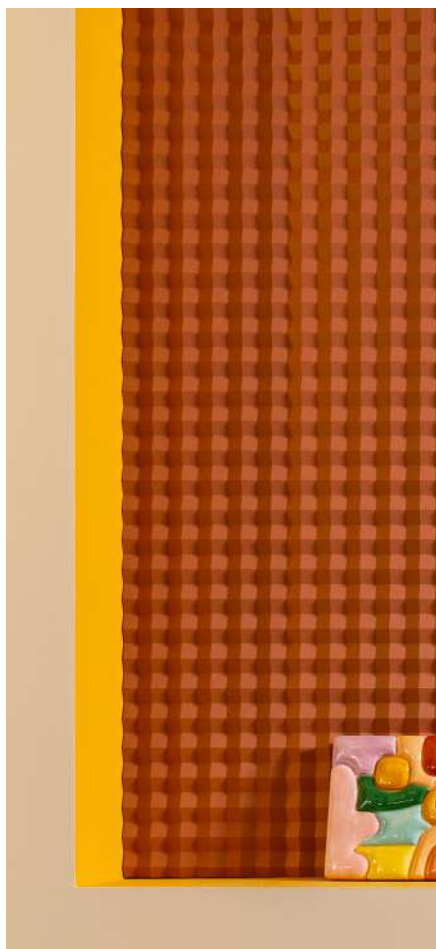

EN –

## 9 Unexpected possibilities

- 12 About today
- 22 Uncut modern
- 32 Vibrant allure
- 44 Essential still

## 57 Products

- 58 Materials
- 62 Product Overview
- 64 — 01 Cornice mouldings
- 94 — 02 3D Wall covering
- 112 — 03 Skirting boards
- 126 — 04 Panel mouldings
- 140 — 05 Indirect lighting
- 156 — 06 Deco elements
- 166 — 07 The perfect finish
- 170 — 08 Flexible products

NL –

## 9 Onverwachte mogelijkheden

- 12 Over vandaag
- 22 Onversneden modern
- 32 Levendige allure
- 44 Nog steeds essentieel

## 57 Producten

- 58 Materialen
- 62 Productoverzicht
- 64 — 01 Kroonlijsten
- 94 — 02 3D Wandbekleding
- 112 — 03 Plinten
- 126 — 04 Wandlijsten
- 140 — 05 Indirecte verlichting
- 156 — 06 Decoratieve elementen
- 166 — 07 De perfecte afwerking
- 170 — 08 Flexibele producten



FR –

**9 Des possibilités inattendues**

- 12 À propos d'aujourd'hui
- 22 Moderne à l'état pur
- 32 Allure vibrante
- 44 Essentiel encore

**57 Produits**

- 58 Matériaux
- 62 Aperçu produits
- 64 — 01 Corniches
- 94 — 02 Revêtements muraux 3D
- 112 — 03 Plinthes
- 126 — 04 Cimaises
- 140 — 05 Éclairage indirect
- 156 — 06 Éléments décoratifs
- 166 — 07 La finition parfaite
- 170 — 08 Produits flexibles

DE –

**9 Unerwartete Möglichkeiten**

- 12 Über das Heute
- 22 Unverfälscht modern
- 32 Lebendige Anziehungskraft
- 44 Immer essentiell

**57 Produkte**

- 58 Materialien
- 62 Produktübersicht
- 64 — 01 Stuckleisten
- 94 — 02 3D Wandvertäfelung
- 112 — 03 Sockelleisten
- 126 — 04 Wand- und Friesleisten
- 140 — 05 Indirekte Beleuchtung
- 156 — 06 Zierelemente
- 166 — 07 Die perfekte Installation
- 170 — 08 Biegbare Produkte

ES –

**9 Posibilidades inesperadas**

- 12 Sobre el presente
- 22 Moderno sin cortes
- 32 Atractivo vibrante
- 44 Todavía esencial

**57 Productos**

- 58 Materiales
- 62 Resumen de productos
- 64 — 01 Cornisas
- 94 — 02 Revestimientos de pared 3D
- 112 — 03 Zócalos
- 126 — 04 Molduras
- 140 — 05 Iluminación indirecta
- 156 — 06 Elementos decorativos
- 166 — 07 El acabado perfecto
- 170 — 08 Productos flexibles

# About today

At times, the modern is inclined to the here and now. Freed from the transience of fashion, it reveals a classic for the future. We are delighted to see it happen. The legacy of an era is revisited to create something new.

**NL –**

Momenten waarop de frisse geest van het nieuwe de echo's van traditie ontmoet. Ontdek hoe, op basis van de erfenis van een tijdperk, de klassiekers van morgen ontvouwen. Een erfgoed opnieuw bezocht, met een stoutmoedige aanraking die hulde brengt aan het heden en een knipoog geeft naar de toekomst.

**DE –**

Zuweilen tendiert die Moderne zum aktuellen Trend. Befreit von der Vergänglichkeit der Mode, entpuppt sie sich als Klassiker für die Zukunft. Wir freuen uns zu sehen, wie das geschieht. Das Erbe einer Ära wird wieder aufgegriffen, um etwas Neues zu schaffen. Eine gewagte Hommage an die Gegenwart und die Zukunft.

**FR –**

Parfois, le moderne est tourné vers le présent. Libéré de l'éphémère de la mode, il révèle un classique pour l'avenir. Nous sommes ravis de voir cela se produire. L'héritage d'une époque est revisité pour créer quelque chose de nouveau. Une touche d'audace en hommage au présent et à demain.

**ES –**

A veces, lo moderno se inclina hacia el presente. Liberándose de la moda efímera y revelando un clásico para el futuro. Estamos encantados de que así sea. El legado de una época se reinterpreta para crear algo nuevo. Un toque atrevido en homenaje al presente y al mañana.



1. **C990** p.77 2. **CX188** p.150 3. **PX209** p.137 4. **W217** p.101 5. **W218** p.101 6. **SX182** p.137

**NL** —  
Wit ontmoet primaire kleuren: een gedurfd, contrasterend samenspel.

**FR** —  
Le blanc rencontre les couleurs primaires : un jeu audacieux et contrasté.

**DE** —  
Weiß trifft auf Primärfarben: Ein mutiges, kontrastreiches Zusammenspiel.

**ES** —  
El blanco se une a los colores primarios: un juego atrevido y lleno de contrastes.

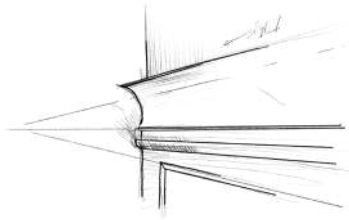

C990 INFINITY + CX188

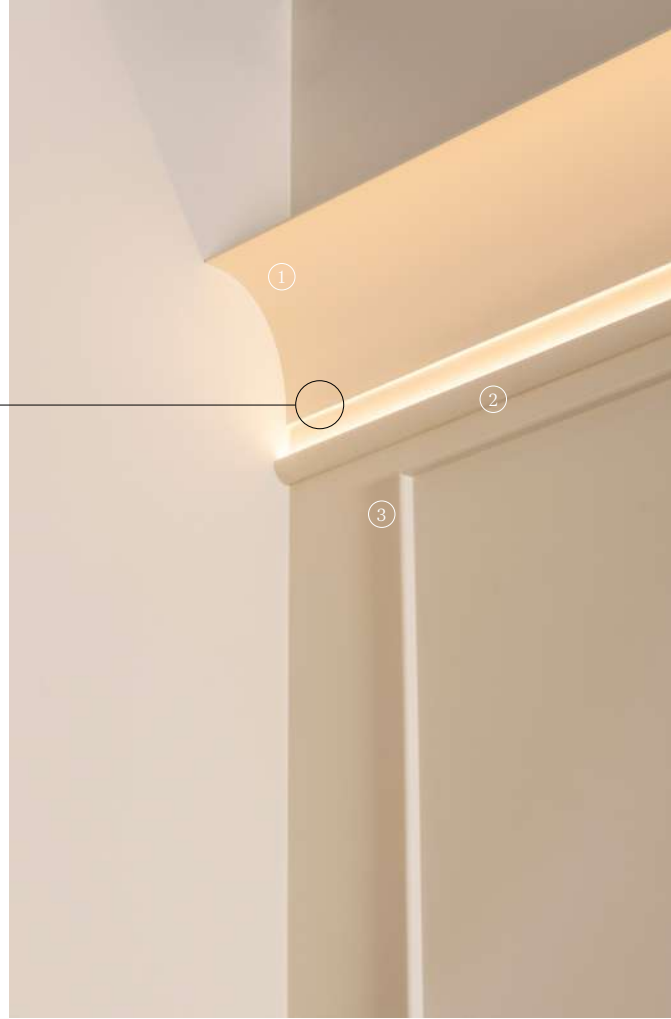

1. C990 p.77 2. CX188 p.150 3. PX209 p.137

3. PX209 p.137



White meets  
primary colours:  
a bold, contrasting  
interplay.

**NL—**  
Grote 3D-vormen zorgen voor een gedurfde esthetische ruimte.

**FR—**  
Des formes 3D importantes façonnent un espace au design audacieux.

**DE—**  
Große 3D-Formen schaffen einen kühnen, ästhetischen Raum.

**ES—**  
Las grandes formas tridimensionales esculpen un espacio atrevido e impactante.

<sup>1</sup> **W115** p.104



Large 3D shapes  
carve out a boldly  
aesthetic space.

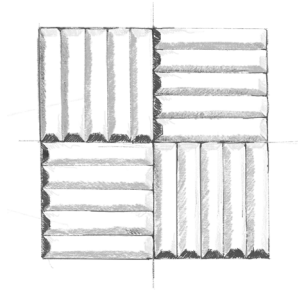

W218 QUILT

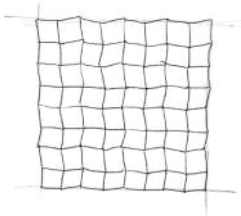

W115 SLOPE



2. W218 p.101 3. W217 p.101 4. SX182 p.137

# The Hub

GHENT (BE)

Project

ORAC

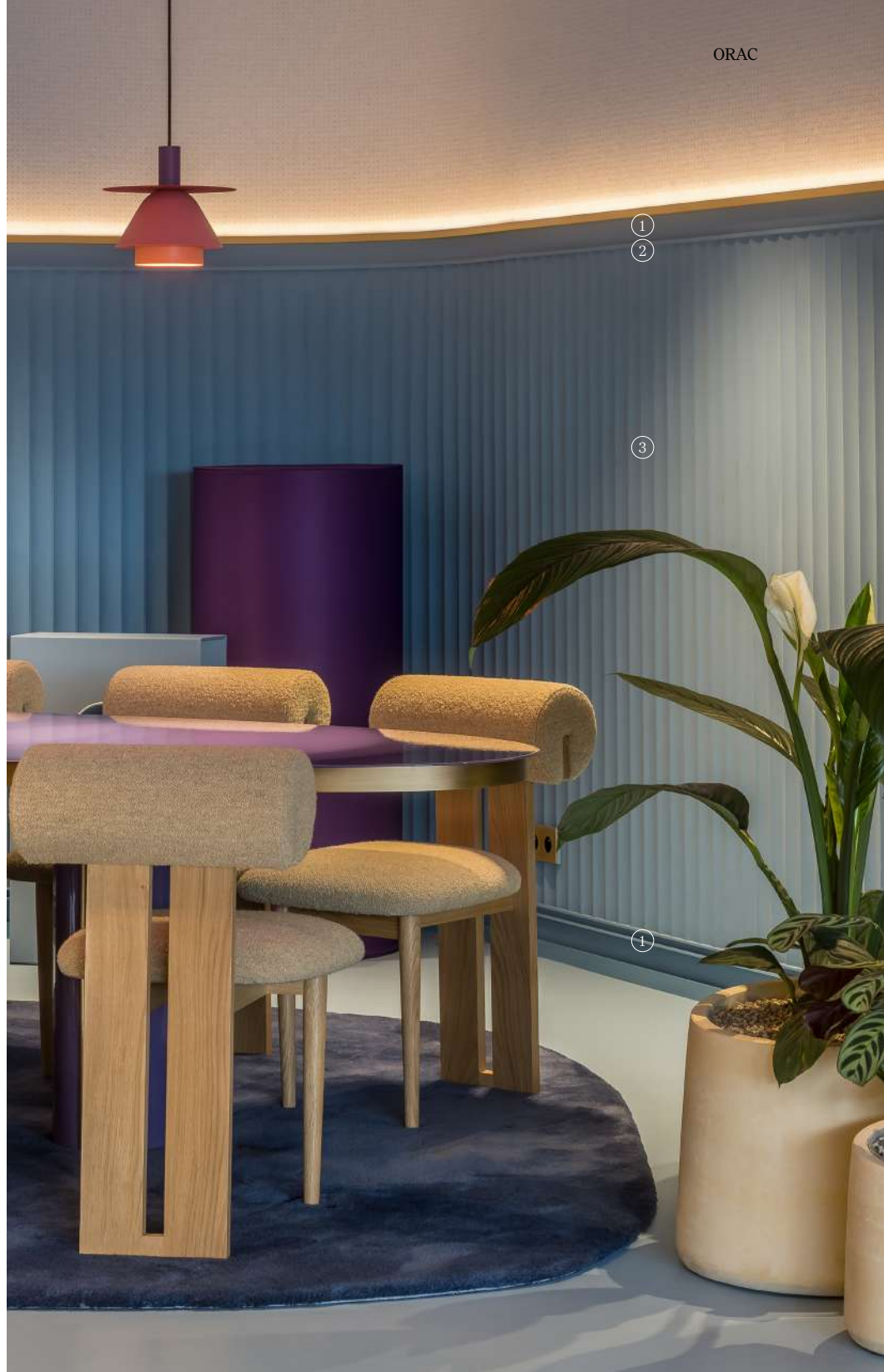

1. CX190 | CX190F p.150 2. SX194 | SX194F p.137 3. W114 | W114F p.100

**NL —**  
Eclectische mix van afgeronde  
3D-panels en levendige kleur-  
contrasten.

**FR —**  
Mélange éclectique de panneaux 3D  
arrondis et de contrastes de couleurs  
vives.

**DE —**  
Eine eklektische Mischung aus  
abgerundeten 3D-Paneelen und  
lebhaften Farbkontrasten.

**ES —**  
Mezcla ecléctica de paneles 3D con  
formas redondeadas y vivos contrastes  
de color.

Eclectic blend of rounded 3D panels and vivid colour contrasts.

<sup>1</sup> CX190 | CX190F p.150   <sup>2</sup> SX194 | SX194F p.137   <sup>3</sup> W114 | W114F p.100



Each room a vibrant canvas with 3D textured walls, daringly immersive. We invite you to dive in and explore.



1. W110 p.98

1. W110 p.98



**NL —**  
Elke kamer wordt een levendig canvas met 3D-textuurwanden. Gedurfd en meeslepend. We nodigen je uit om je erin onder te dompelen.

**FR —**  
Chaque pièce est une toile vibrante avec des murs 3D texturés, offrant une immersion audacieuse. Nous vous invitons à plonger dans cet univers, si vous le souhaitez.

**DE —**  
Jeder Raum ist eine lebendige Leinwand mit beeindruckend, texturierten 3D-Wänden. Wir laden Sie ein, einzutauchen, wenn Sie möchten.

**ES —**  
Cada habitación es un lienzo vibrante con paredes texturizadas en 3D, atrevidamente envolventes. Te invitamos a sumergirte, si quieres.

1. W110 p.98



# Uncut modern

NL —

We zijn voortdurend geraakt door de bijzondere prestaties van de moderne tijd. De vooruitstrevendheid van de geest. De manier waarop bescheidenheid samenvloeit met subtiële grootsheid. We volgen met liefde strakke lijnen, hechten waarde aan minimalistische elegantie en brutalistische durf. Onze liefde voor moderniteit stimuleert ons oog voor detail.

DE —

Wir sind immer wieder von den einzigartigen Errungenschaften der Moderne bewegt. Die Fortschrittlichkeit des Geistes. Die Art und Weise, wie sich Bescheidenheit mit subtiler Erhabenheit verbindet. Wir ziehen liebevoll klare Linien nach, schätzen minimalistische Anmut und brachiale Verwegenheit. Unsere Vorliebe für die Moderne fördert unsere Aufmerksamkeit für Details.

FR —

Nous sommes perpétuellement émus par les réalisations singulières de l'ère moderne. La progressivité de l'esprit. La façon dont la modestie se mêle à la grandeur subtile. Nous traçons avec amour des lignes épurées, nous apprécions la grâce minimaliste et l'audace brute. Notre goût pour la modernité nous incite à soigner les détails.

ES —

No dejan de conmovernos los logros únicos de la era moderna. La mentalidad progresista. La forma en que la modestia se mezcla con una sutil grandeza. Delineamos líneas limpias, apreciamos la elegancia minimalista y la audacia brutalista. Nuestra pasión por la modernidad fomenta nuestra atención al detalle.

We are perpetually moved by the singular achievements of the modern age. The progressiveness of the mind. The way modesty blends with subtle grandeur. We lovingly trace clean lines, value minimalist grace and brutalist audacity. Our affection for modernity encourages our attentiveness to detail.



NL —

Strakke lijnen, hoekige vormen en minimalistische elegantie in moderne harmonie.

FR —

Des lignes épurées, des formes anguleuses et une élégance minimaliste dans une harmonie moderne.

DE —

Schlanke Linien, kantige Formen und minimalistische Eleganz in moderner Harmonie.

ES —

Líneas depuradas, formas angulosas y elegancia minimalista en moderna armonía.

Sleek lines, angular shapes and minimalist elegance in modern harmony.

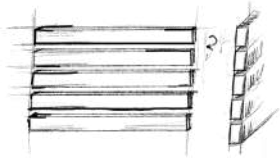

W111 BAR



- 4 C391 p.79
- 5 C393 p.145
- 6 W111 p.103
- 7 W116 p.103
- 8 W119 p.103
- 9 CX190 p.118



- 1. **C391** p.79
- 2. **C393** p.145
- 3. **CX190** p.118
- 4. **W216** p.104
- 5. **SX207** p.137

**NL** —  
Moderne art deco vibe:  
een ingetogen, gelaagde elegantie.

**FR** —  
L'ambiance art déco moderne :  
une élégance discrète et stratifiée.

**DE** —  
Modernes Art-Déco-Gefühl:  
Schlichte, vielschichtige Eleganz.

**ES** —  
Ambiente art déco moderno:  
una elegancia discreta y estratificada.

Modern Art Deco vibe:  
an understated,  
layered elegance.

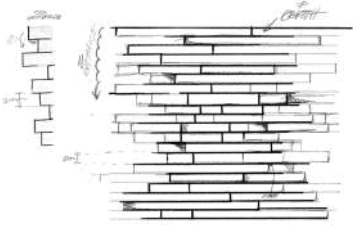

W216 MATRIX

7. C392 p.79 8. C390 p.79 9. P7070 p.130 10. SX180 p.118

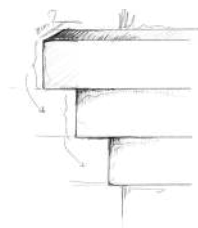

P7070



<sup>1</sup> CX190 p.118

Symmetry  
reimagined:  
U-profiles dance on  
walls and gracefully  
embrace ceilings.

## Unexpected possibilities

NL —

Een nieuwe vorm van symmetrie: U-profielen dansen op muren en omarmen sierlijk plafonds.

FR —

La symétrie revisitée : les profilés en U dansent sur les murs et embrassent gracieusement les plafonds.

DE —

Symmetrie neu interpretieren: U-Profile zieren die Wände und umfassen grazil die Decken.

ES —

Simetría reinterpretada: Los perfiles en forma de U bailan en las paredes y abrazan con elegancia los techos.



2. CX190 | CX190F p.118



2. CX190F p.118



1. SX180 p.118

Stepped lines  
translate a modern  
Art Deco vision from  
floor to ceiling.

1. SX180 p.118 2. CX188 p.150 3. C393 p.79 4. C394 p.79 5. C391 p.79



**NL —**  
Trapsgewijze lijnen vertalen een moderne art deco visie van vloer tot plafond.

**FR —**  
Les lignes en escalier traduisent une vision art déco moderne du sol au plafond.

**DE —**  
Abgestufte Linien übermitteln eine moderne Art-Déco-Vision vom Boden bis zur Decke.

**ES —**  
Las líneas escalonadas transmiten una visión art déco moderna de suelo a techo.



<sup>6</sup>. C991 + 2xP9900 p.77 <sup>7</sup>. CX188 p.150

# Vibrant allure

**NL —**

We houden ervan om binnen te stappen in een wereld van kunstzinnige verrassingen, waar klassieke elegantie en gedurfde, gewaagde wendingen samenkomen en een unieke ervaring creëren. Een wereld van het onverwachte, waar raffinement en eigenzinnigheid samensmelten in een feest van creativiteit.

**FR —**

Nous aimons explorer un univers d'art surprenant, mêlant l'élégance classique à l'audace pour créer une expérience unique. Un royaume imprévisible, où sophistication et fantaisie se rencontrent pour célébrer la créativité.

**DE —**

Wir lieben es, in eine Welt voller kunstvoller Überraschungen einzutauchen, in der klassische Eleganz auf gewagte, mutige Wendungen trifft und ein einzigartiges Erlebnis schafft. Ein Reich des Unerwarteten, in dem Eleganz auf Fantasie trifft, um die Kreativität zu feiern.

**ES —**

Nos encanta adentrarnos en un mundo de sorpresas artísticas, donde la elegancia clásica se une a giros atrevidos y audaces, creando una experiencia única. Un reino de lo inesperado, donde la sofisticación se une al capricho en una celebración de la creatividad.

We love to step into a world of artful surprises, where classic elegance meets daring, audacious twists, creating a one-of-a-kind experience. A realm of the unexpected, where sophistication meets whimsy in a celebration of creativity.

1. C332 p.74 2. W214 p.98 3. W215 p.98 4. SX138 p.117



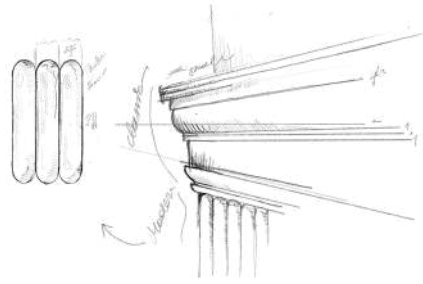

**C332** NOBLESSE  
**W214** HILL BEAD XL

**NL —**  
Een ondeugende botsing van textuur en kleur; levendige patronen en diepe tinten die onverwacht in harmonie zijn.

**FR —**  
Une collision espiègle de textures et de couleurs ; des motifs vibrants et des teintes profondes créant une harmonie inattendue.

**DE —**  
Eine originelle Verbindung von Textur und Farbe; lebendige Muster und tiefe Farbtöne, die eine unerwartete Harmonie bilden.

**ES —**  
Una traviesa colisión de texturas y colores; motivos vibrantes y tonos profundos que crean una armonía inesperada.

A mischievous collision of texture and colour; vibrant patterns and deep hues crafting an unexpected harmony.



1. C332 p.74 2. W215 p.98 3. SX138 p.117 4. W214 p.98 5. W110 p.98 6. PX209F p.137 7. WX210F p.97 8. WX211F p.97



2. W215 p.98 3. SX138 p.117 4. W214 p.98



Walls oozing with  
glamour and abundance,  
beckoning you into  
their captivating  
design narrative.

**NL —**  
Muren die bol staan van glamour  
en overvloed, en je meenemen in  
hun boeiende designverhaal.

**FR —**  
Des murs qui débordent de glamour  
et d'abondance et qui vous invitent  
à entrer dans leur récit captivant.

**DE —**  
Wände, die vor Glamour und Pracht  
nur so strotzen und Ihnen eine  
fesselnde Designgeschichte erzählen.

**ES —**  
Paredes repletas de glamur y  
abundancia, que invitan a adentrarse  
en su cautivadora narrativa de diseño.



<sup>1</sup>. PX175 p.135 <sup>2</sup>. P8030 p.128

**NL —**  
Een contrasterend tafereel: waar sierlijke details en serene tinten zich gedurfd manifesteren.

**FR —**  
Un tableau de contrastes où les détails ornementaux et les teintes sereines s'expriment avec audace.

**DE —**  
Ein Schauspiel der Kontraste, auf dem kunstvolle Details und ruhige Farbtöne gekonnt kombiniert werden.

**ES —**  
Un lienzo de contrastes: donde los detalles ornamentales y los tonos serenos encuentran una relación atrevida.

A canvas of contrast:  
where ornate details  
and serene hues find  
daring expression.



<sup>1</sup> PX175 p.135 <sup>2</sup> P8030 p.128



<sup>3</sup> P3020 p.129 <sup>4</sup> P3020A p.139 <sup>5</sup> P8050 p.128



<sup>1</sup> PX120 p.135 <sup>2</sup> P4020 p.128

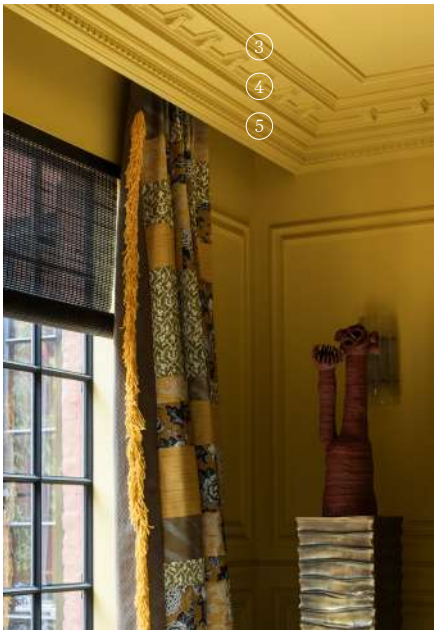

<sup>3</sup> C305 p.70 <sup>4</sup> C307A p.70 <sup>5</sup> C211 p.70

Untamed creativity blooms in a lavish fusion of colour and intricate design.



<sup>1</sup> PX120 p.135 <sup>2</sup> P4020 p.128 <sup>3</sup> C305 p.70 <sup>4</sup> C307A p.70 <sup>5</sup> C211 p.70 <sup>6</sup> DX170-2600 p.162 <sup>7</sup> D330LR p.162

**NL —**  
Ongetemde creativiteit bloeit in een uitbundige samensmelting van kleuren en complexe ontwerpen.

**FR —**  
La créativité sauvage s'épanouit dans une somptueuse fusion de couleurs et de motifs complexes.

**DE —**  
Unbändige Kreativität erblüht in einer großartigen Verschmelzung von Farbe und kunstvollem Design.

**ES —**  
La creatividad indómita florece en una fastuosa fusión de color y diseño intrincado.

Whenever you fancy a change,  
our products are ready for  
a repaint.



1- **PX120** p.135 2- **P4020** p.128 3- **C305** p.70 4- **C307A** p.70 5- **C211** p.70

**NL** —  
Als je zin hebt in verandering,  
dan laten onze producten zich  
makkelijk herschilderen.

**FR** —  
Quand vous avez envie de changer,  
nos produits sont prêts à être repeints.

**DE** —  
Wann immer Sie Lust auf eine Ver-  
änderung haben, sind unsere Produkte  
bereit für einen neuen Anstrich.

**ES** —  
Cada vez que desees un cambio,  
nuestros productos eran listos para  
una transformación cromática.



# Essential still

We love to embrace the timeless charm of bygone eras as it speaks fluently in the language of today. A demonstration of how classic forms can be reinterpreted to remain ever-relevant.

**NL —**

We houden er zo van wanneer de tijdloze charme van vervlogen tijden vloeiend spreekt in de taal van vandaag. Een demonstratie van hoe klassieke vormen kunnen worden geherinterpreteerd om altijd relevant te blijven.

**FR —**

Nous apprécions que le charme intemporel des époques révolues puisse s'exprimer naturellement dans le langage contemporain. Une démonstration de la manière dont les formes classiques peuvent être réinterprétées pour rester toujours pertinentes.

**DE —**

Wir lieben es, wenn der zeitlose Charme vergangener Epochen fließend in die Sprache von heute übergeht. Eine Demonstration, wie klassische Formen neu interpretiert werden können, um immer aktuell zu bleiben.

**ES —**

Nos fascina cuando el encanto atemporal de épocas pasadas habla con fluidez el lenguaje de hoy. Una demostración de cómo las formas clásicas pueden reinterpretarse para seguir siendo siempre actuales.

<sup>1</sup>. C343 p.66 <sup>2</sup>. P8020 p.128 <sup>3</sup>. P4020 p.128 <sup>4</sup>. SX206 p.117



NL —

Verfijnde elementen in een alles-behalve willekeurige volgorde op de muur stralen evenwicht en rust uit.

FR —

Des éléments raffinés, disposés sur le mur dans un ordre qui n'a rien d'arbitraire, dégagent un équilibre et une présence tranquille.

DE —

Edle Elemente in einer alles andere als willkürlichen Reihenfolge an der Wand wirken ausgewogen und doch präsent

ES —

Elementos sofisticados dispuestos en una secuencia cuidadosamente diseñada que irradia equilibrio y tranquilidad.

C343 HERITAGE

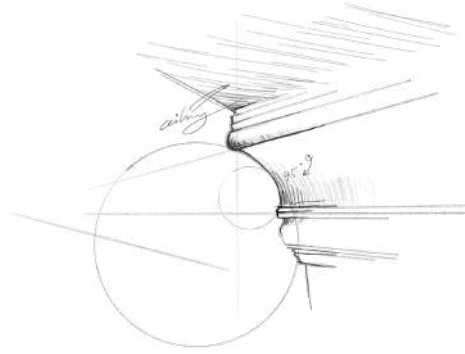

Refined elements,  
in a far from arbitrary  
sequence on the wall,  
exude balance and  
discrete presence.





1. **W109** p.100 2. **P9010** p.128 3. **P9050** p.130 4. **SX155** p.130

**NL** —  
Strakke elegantie in elke lijn die een  
sfeer van kalme verfijning creëert.

**FR** —  
Une grâce suspendue dans chaque  
ligne, créant une atmosphère de  
calme et de sophistication.

**DE** —  
Jede Linie vermittelt eine gelassene  
Anmut und schafft eine Atmosphäre  
von ruhiger Raffinesse.

**ES** —  
Elegancia equilibrada en cada línea,  
creando un ambiente de sofisticada  
serenidad.

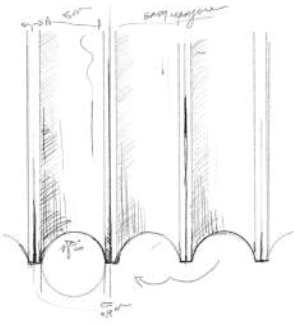

W109 VALLEY

Poised grace in every line,  
creating an atmosphere of  
calm sophistication.

1. W109 p.100 2. P9010 p.128 3. P9050 p.130





1. P8050 p.128



3. C305 p.70 4. C307A p.70 5. C211 p.70

**NL —**  
Torenhoge plafonds bekroond met grote kroonlijsten vertellen een verhaal van tijdloze weelde.

**FR —**  
Les hauts plafonds couronnés de grandes corniches offrent une image d'opulence intemporelle.

**DE —**  
Hoch ragende Decken, gekrönt von prächtigen Stuckleisten, vermitteln einen Eindruck von zeitloser Opulenz.

**ES —**  
Los altísimos techos coronados con grandes cornisas ofrecen un relato de opulencia atemporal.

Towering ceilings  
crowned with grand  
cornices offer a narrative  
of timeless opulence.

2. **PX175** p.135 3. **C305** p.70 4. **C307A** p.70 5. **C211** p.70 6. **P8030** p.128 7. **SX191** p.119





1- C343 p.66 2- P8020 p.128 3- P4020 p.128 4- SX191 p.119 5- DX170-2600 p.162 6- D330LR p.162

Grandeur in every detail, framed by a bold monochromatic use of saturated colours.



<sup>1</sup> C343 p.66 <sup>2</sup> P8020 p.128 <sup>3</sup> P4020 p.128 <sup>4</sup> SX191 p.119

**NL —**  
Grandeur in elk detail, omlijst door een gedurfd monochroom gebruik van verzadigde kleuren.

**FR —**  
La grandeur dans chaque détail, encadrée par une utilisation monochromatique audacieuse de couleurs saturées.

**DE —**  
Jedes Detail wirkt prachtvoll und wird von einer kühnen monochromen Verwendung gesättigter Farben eingerahmt.

**ES —**  
Grandeza en cada detalle, enmarcado por un atrevido uso monocromático de colores saturados.

<sup>1</sup> P8030 p.128 <sup>2</sup> CX160 p.91 <sup>3</sup> C332 p.74

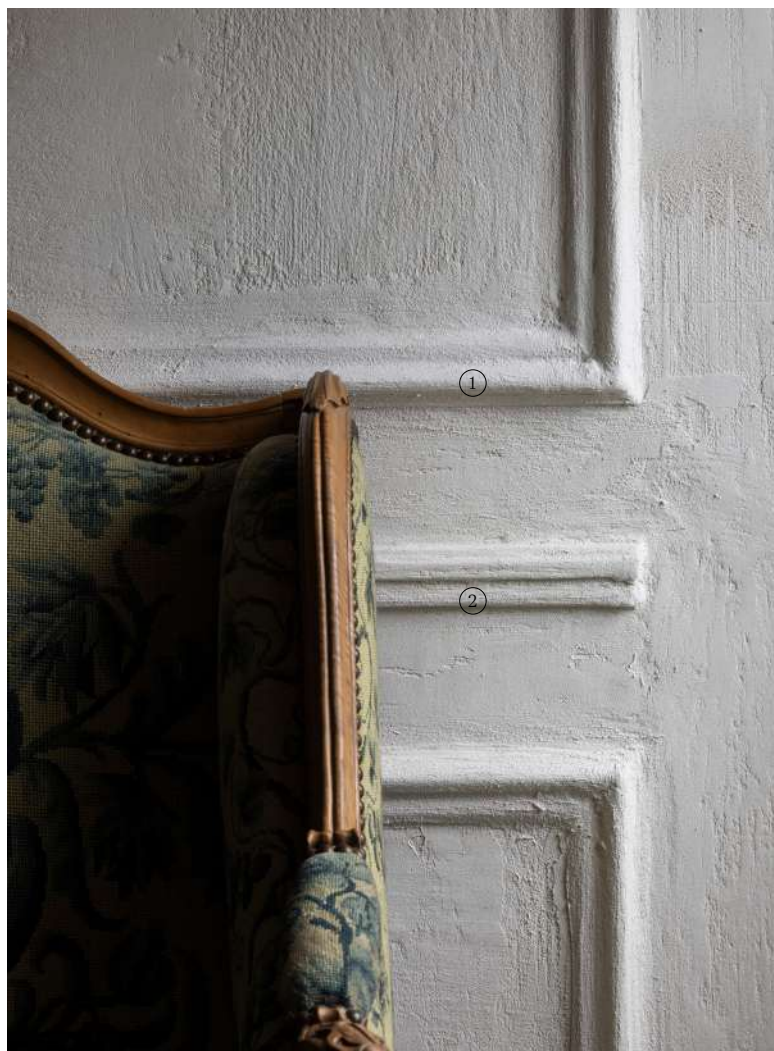

Enhance our products with textured paint for an artisanal finish that adds depth and character to any room.

**NL —**

Je kan het design van onze producten kracht bijzetten met textuurverf voor een artisanale look die diepgang en karakter aan elke ruimte geeft.

**FR —**

Rehaussez nos produits avec de la peinture texturée pour une finition artisanale qui ajoute de la profondeur et du caractère à n'importe quelle pièce.

**DE —**

Veredeln Sie unsere Produkte mit Strukturfarbe für ein handwerkliches Finish, das jedem Raum Tiefe und Charakter verleiht.

**ES —**

Eleva nuestros productos con pintura texturizada para un acabado artesanal que aporta profundidad y carácter a cualquier habitación.



3



# Products

Discover our architectural elements, made for walls. Every product is an innovation with user ease in mind, designed to enhance and transform interiors. We propose a palette that matches styles and meets ideas. So that your walls can become the canvas for your imagination.

**NL –**

We stellen u graag voor aan onze architecturale elementen, ontworpen voor muren. Elk product is een innovatie met gebruiksgemak in het achterhoofd, ontworpen om interieurs kracht bij te zetten. We leggen een palet voor dat bij stijlen aansluit en ideeën tegemoet komt. Zodat je muren het canvas voor je verbeelding kunnen worden.

**FR –**

Nous vous invitons à découvrir nos éléments architecturaux, faits pour les murs. Chaque produit est une innovation qui vise à faciliter la vie de l'utilisateur, conçu pour améliorer et transformer vos intérieurs. Nous proposons une palette qui s'harmonise avec les styles et répond aux idées. Pour que vos murs deviennent la toile de votre imagination.

**DE –**

Entdecken Sie unsere architektonischen Elemente für Ihre Wände. Jedes Produkt ist eine Innovation. Entwickelt für Nutzerfreundlichkeit, um Innenräume zu bereichern und zu verwandeln. Wir präsentieren eine Produktreihe, die zu jedem Stil passt und Ideen verwirklicht. Damit Ihre Wände zu einer Leinwand für Ihre Fantasie werden können.

**ES –**

Descubre nuestros elementos arquitectónicos creados para paredes. Cada producto es innovador, y esta pensado para facilitar su uso y diseñado para transformar interiores. Proponemos una paleta que armoniza con distintos estilos y satisface tus ideas. Así, tus paredes pueden convertirse en el lienzo de tu imaginación.

# Materials

In-house engineered material compositions

INGENIEUZE MATERIALEN  
MATÉRIAUX TECHNIQUES  
DURCHDACHTE MATERIALEN  
MATERIALES DE INGENIERÍA

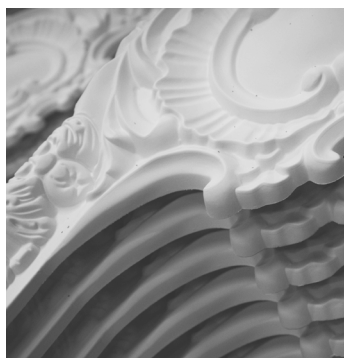

## PUROTOUCH®

A high-quality, medium-density polyurethane that allows fine details.

Een kwalitatieve polyurethaan van hoge densiteit die scherpe details mogelijk maakt — Un polyuréthane de qualité à haute densité qui permet de créer des détails fins — Ein qualitativ hochwertiges Polyurethan hoher Dichte, das schöne Details möglich macht — Poliuretano de alta densidad y calidad con el que crear ambientes exclusivos.

Detail Design ☆☆☆

Impact Resistance ☆☆

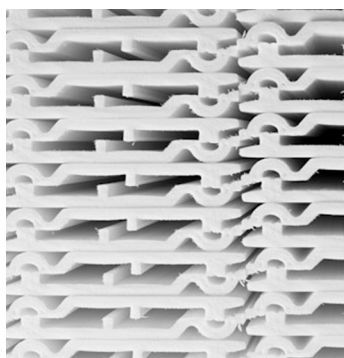

## DUROPOLYMER®

An extruded and impact-resistant polymer based on a high-density polystyrene.

Geëxtrudeerde en impactbestendige polystyreenmix van hoge densiteit — Un polymère extrudé résistant aux impacts à base d'un mélange de polystyrènes haute densité — Extrudierter und schlagfester, hochdichter Polystyrol-Mix — Polímero fabricado por extrusión, resistente a impactos fuertes a base de una mezcla de poliestireno de alta densidad.

Detail Design ☆☆

Impact Resistance ☆☆☆



## DUROFOAM®

An extruded lightweight polymer based on a low-density polystyrene blend.

Geëxtrudeerde lichtgewicht polystyreenmix van medium densiteit — Un polymère léger extrudé à base d'un mélange de polystyrènes de densité moyenne — Extrudiertes, leichtes Polymer auf der Grundlage eines Polystyrol-Mix mittlerer Dichte — Polímero fabricado por extrusión de peso ligero a base de una mezcla de poliestireno de densidad baja.

Detail Design ☆

Impact Resistance ☆



## FLEX

A quality high-density flexible polyurethane.

Een kwalitatieve flexibele polyurethaan van hoge densiteit — Un polyuréthane flexible de haute densité et qualité — Ein hochwertiger, hochdichter flexibler Polyurethanschaum — Poliuretano moldeado flexible de alta calidad y densidad.

Detail Design ☆☆☆

Impact Resistance ☆☆☆

## READY TO PAINT

All of our products are ready to paint. Coloured end finishes on demand.

Al onze producten worden schilderklaar geleverd. Kleuren op aanvraag — Tous nos produits sont prêts à peindre. Couleurs sur demande — Alle unsere Produkte sind bereit zum Beschichten. Farben auf Anfrage — Todos nuestros productos están listos para ser pintados. Colores bajo demanda.



VOORDELEN  
AVANTAGES  
VORTEILE  
VENTAJAS

Advantages



## DURABLE

Orac products are designed to last a lifetime. Smart design and high-end technology assure strong and water resistant products.

Orac producten zijn ontwikkeld om een leven lang mee te gaan. Slim productdesign en state-of-the-art technologie verzekeren sterke en waterbestendige producten — Les produits sont conçus pour durer toute une vie. Une conception intelligente et une technologie haut de gamme garantissent des produits robustes et résistants à l'eau — Orac-Produkte halten ein Leben lang. Intelligentes Design und hochwertige Technologie sorgen für robuste und absolut wasserbeständige Produkte — Los productos de Orac están diseñados para durar toda la vida. Gracias a su diseño sofisticado y la tecnología de vanguardia, se trata de productos sólidos y resistentes al agua.

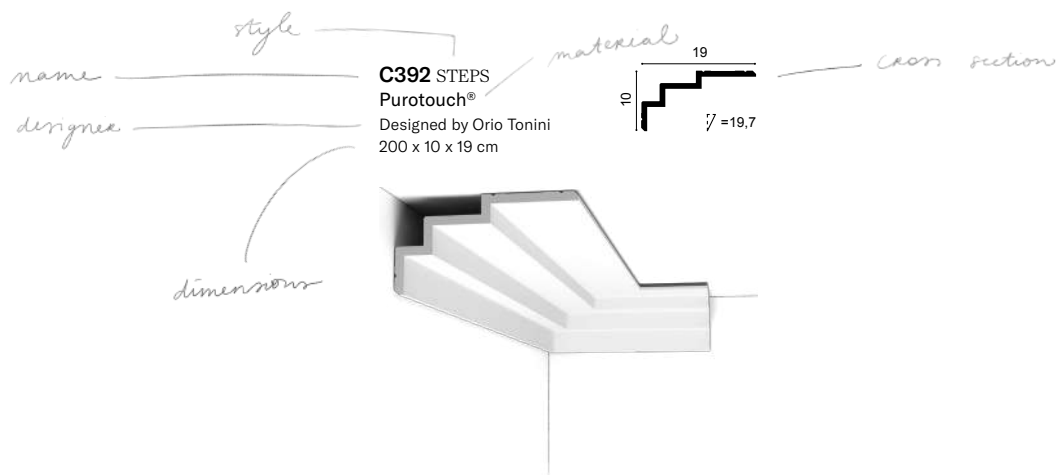

Legend

At Orac, our vision is to become restorative by 2050. This ambitious goal drives our material choices and operational practices, ensuring that every step we take not only minimizes environmental harm but actively contributes to ecological restoration. Since 2018 we have been making profound changes in the full lifecycle of our products. From selection and use of raw materials all the way to our production process.

— There are many sides to walls. We go for the good side.

**NL —**

Bij Orac is het de visie om restoratief te worden tegen 2050. Dit ambitieuze doel is de drijfveer van onze materiaalkeuzes en operationele praktijken en zorgt ervoor dat elke stap die we zetten niet alleen schade aan het milieu beperkt, maar ook actief bijdraagt aan ecologisch herstel. Sinds 2018 hebben we ingrijpende veranderingen doorgevoerd in de volledige levenscyclus van onze producten. Van de selectie en het gebruik van grondstoffen en materialen tot aan ons productieproces. — Muren hebben vele kanten. Wij gaan voor de goede kant.

**FR —**

Chez Orac, notre vision est de devenir réparateur d'ici à 2050. Cet objectif ambitieux oriente nos choix de matériaux et nos pratiques opérationnelles, en veillant à ce que chaque mesure que nous prenons non seulement minimise les dommages à l'environnement, mais contribue aussi activement à la restauration écologique. Depuis 2018, nous avons fait de changements profonds au cycle de vie complet de nos produits. De la sélection et de l'utilisation des matières premières jusqu'à notre processus de production. — Les murs ont beaucoup de côtés. Nous choisissons le bon côté.

**DE —**

Orac hat die Vision, bis zum Jahr 2050 restaurativ zu werden. Dieses ehrgeizige Ziel treibt unsere Materialauswahl und betriebliche Praktiken, um sicherzustellen dass jeder Schritt, den wir unternehmen, nicht nur den Schaden für die Umwelt minimiert, sondern aktiv zur ökologischen Wiederherstellung beiträgt. Seit 2018 haben wir tiefgreifende Veränderungen im gesamten Lebenszyklus unserer Produkte vorgenommen. Von der Auswahl und Verwendung von Rohstoffen bis hin zu unserem Produktionsprozess. — Eine Wand hat viele Seiten. Wir entscheiden uns für die gute Seite.

**ES —**

En Orac, nuestro objetivo es llegar a tener un impacto positivo en 2050. Este ambicioso objetivo impulse nuestra elección de materias primas y procedimientos operativos, garantizando que cada paso que damos no solo minimiza el daño medioambiental, sino que contribuye a la restauración ecológica. A partir de 2018 hemos estado realizando cambios significativos en el ciclo de vida de nuestros productos, desde la selección y el uso de materias primas hasta nuestro proceso de producción. — Las paredes tienen muchas caras. Nosotros nos decantamos por la buena.



### DEFOSSILISATION PROCESS

Orac's design merge recycled, bio-based and plant-based materials, emphasizing sustainable innovation.



### SUSTAINABLE OPERATIONS

Orac has been CO<sub>2</sub> neutral for the full scope 1 and 2 since 2021, working towards climate positivity by 2050.



### BUILT TO LAST, BUILT RESPONSIBLY

Our durable products with a lasting lifetime support a sustainable, circular economy.



### MORE THAN WALLS

Orac's commitment to sustainability extends to community engagement and social responsibility.



# Product overview



01

p. 64

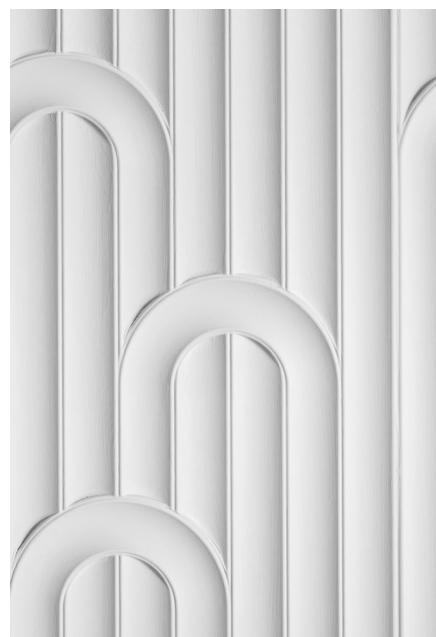

02

p. 94



05

p. 140



06

p. 156

- 01 Cornice mouldings
- 02 3D Wall covering
- 03 Skirting boards
- 04 Panel mouldings
- 05 Indirect lighting
- 06 Deco elements
- 07 The perfect finish
- 08 Flexible products



03

p. 112



04

p. 126



07

p. 166



08

p. 170

# Cornice mouldings

01



KROONLIJSTEN  
CORNICHES  
STUCKLEISTEN  
CORNISAS

It truly does move us when we look up and see how it softens the strict transition between wall and ceiling. For us, a cornice is about attention to detail, be it from ornate to subtle. We have thought them all through so that there should always be an option that meets your personal aspirations.

**NL –**

Omhoog kijken en zien hoe de overgang tussen muur en plafond verzacht wordt. Dat beroert ons. Voor ons draait een kroonlijst om aandacht voor detail. Van sierlijk tot subtiel. Elk design goed doordacht zodat er altijd een optie is die aansluit op je persoonlijke wensen.

**FR –**

C'est véritablement captivant. En levant les yeux, on remarque comment elle adoucit la transition stricte entre le mur et le plafond. Pour nous, une corniche incarne un souci minutieux du détail, que ce soit dans l'ornementation ou dans la subtilité. Chaque option a été soigneusement pensée pour répondre à vos aspirations personnelles.

**DE –**

Das bewegt uns wahrhaftig: Wenn wir nach oben schauen und sehen, wie der harte Übergang zwischen Wand und Decke aufgelockert wird. Für uns ist ein Gesims eine Frage der Liebe zum Detail. Von verschnörkelt bis dezent. Wir haben sie alle berücksichtigt. Daher sollte es immer eine Möglichkeit geben, die Ihren persönlichen Ansprüchen entspricht.

**ES –**

Es realmente conmovedor cuando miramos hacia arriba y vemos cómo suaviza la estricta transición entre pared y techo. Para nosotros, una cornisa es sinónimo de atención al detalle. De lo ornamentado a lo sencillo. No hemos dejado nada al azar, para que siempre haya una opción que satisfaga tus deseos.

**C341 | C341F HERITAGE**  
Purotouch®  
200 x 8,8 x 12,2 cm

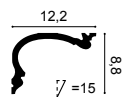

**C342 HERITAGE**  
Purotouch®  
200 x 14 x 19 cm

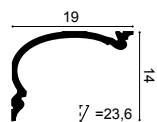

① **C343 HERITAGE**  
Purotouch®  
200 x 19 x 25 cm

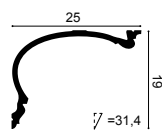

**C344 HERITAGE**  
Purotouch®  
200 x 27,3 x 35 cm

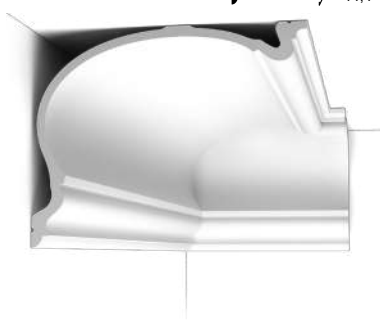
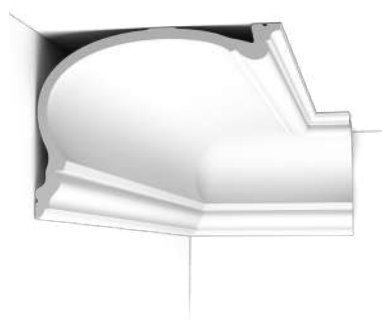
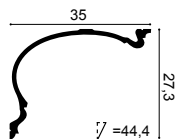

1. C343 2. P8020 p.128





Cornice mouldings

1. C327 2. P8030 p.128 3. P8020 p.128 4. SX191 p.119

**C325 MANOIR**  
Purotouch®  
200 x 7 x 6,5 cm

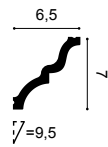

**C326 MANOIR**  
Purotouch®  
200 x 10,5 x 9 cm

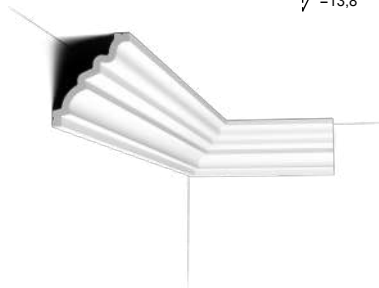
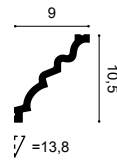

**C327 MANOIR**  
Purotouch®  
200 x 14,3 x 15,9 cm

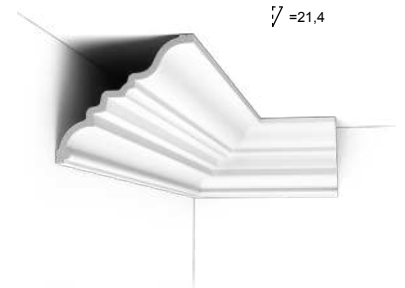
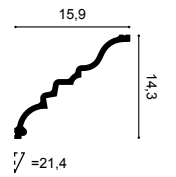

**C338 BA'ROCK**  
Purotouch®  
200 x 18,2 x 18,2 cm

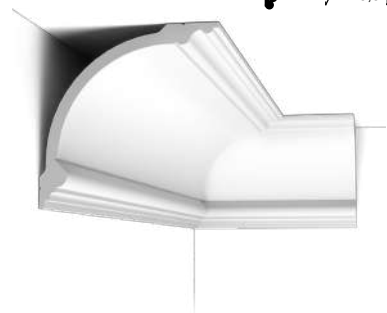
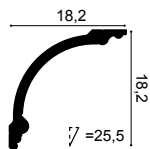

**C338A BA'ROCK**  
Purotouch®  
200 x 18,2 x 18,2 cm  
Dessin: 120 cm

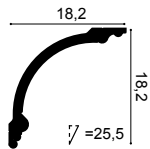

**C338B BA'ROCK**  
Purotouch®  
200 x 18,2 x 18,2 cm  
Dessin: 2 x 57 cm

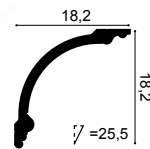

**C336 BA'ROCK**  
Purotouch®  
200 x 27,1 x 26,6 cm

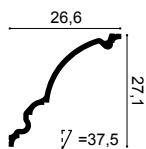

1. C217



**C230 | C230F**  
Purotouch®  
200 x 2,9 x 2,9 cm

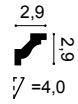

**C215 | C215F**  
Purotouch®  
200 x 4,7 x 4,7 cm

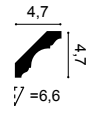

**C322**  
Purotouch®  
200 x 5 x 4,2 cm

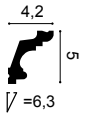

**C328** NEW  
Purotouch®  
200 x 9 x 6,8 cm

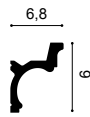

**C200**  
Purotouch®  
200 x 6,5 x 5,7 cm

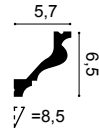

**C220 | C220F**  
Purotouch®  
200 x 7,6 x 11,6 cm

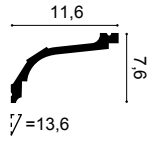

**C213 | C213F**  
Purotouch®  
200 x 8 x 8 cm

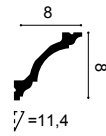

① **C217 | C217F**  
Purotouch®  
200 x 15,6 x 10,3 cm

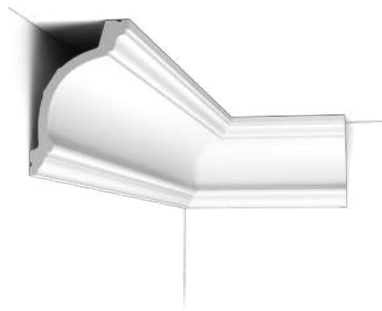
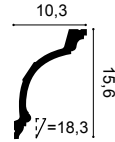

**C217 | C217F** ↗ 90°  
Purotouch®  
200 x 10,3 x 15,6 cm

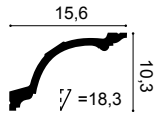

**C216**  
Purotouch®  
200 x 11,6 x 13,3 cm

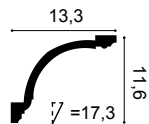

**C301**  
Purotouch®  
200 x 17 x 14,4 cm

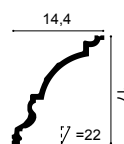

**S425 | S425F SCALLOP** NEW  
Purotouch®  
200 x 15 x 1 cm  
Designed by Roelfien Vos

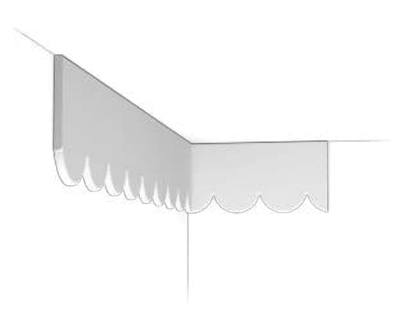

**C305**  
Purotouch®  
200 x 4,7 x 15,5 cm

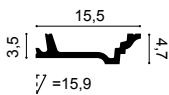

**C305 + C213**

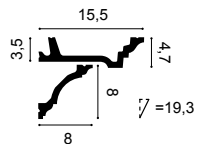

**C305 + C211**

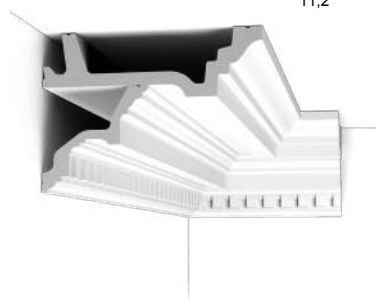
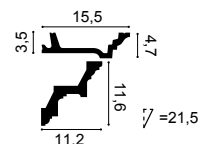

**C211 | C211F**  
Purotouch®  
200 x 11,6 x 11,2 cm

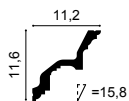

**C422**  
Purotouch®  
200 x 16,4 x 19,4 cm

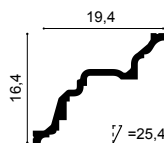

**C307**  
Purotouch®  
200 x 19,5 x 19,5 cm

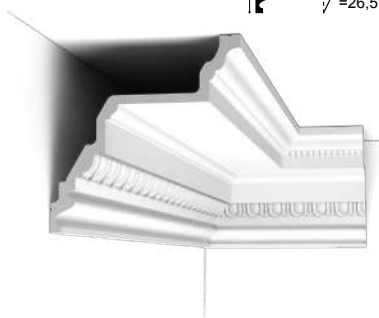
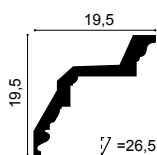

**(A) C307 + C307A (B)**  
Purotouch®  
Duropolymer®  
C307A: 7,5 x 4 x 9,4 cm

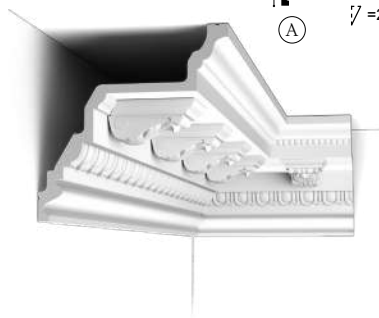
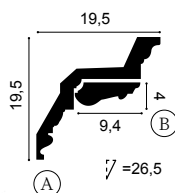



Cornice mouldings

1- PX175 p.135 2- C305 3- C307A 4- C211 5- P8030 p.128 6- SX191 p.119

1 C219



**C333 | C333F**  
Purotouch®  
200 x 12,2 x 11,1 cm

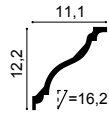

**C331**  
Purotouch®  
200 x 6,1 x 13,5 cm

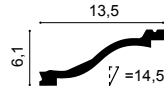

**C334 | C334F**  
Purotouch®  
200 x 15 x 19,6 cm

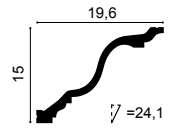

**C902 | C902F**  
Purotouch®  
200 x 10,3 x 10,3 cm

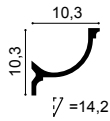

**C901 | C901F**  
Purotouch®  
200 x 14,8 x 12,4 cm

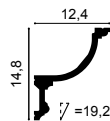

**C900**  
Purotouch®  
200 x 17,1 x 14,6 cm

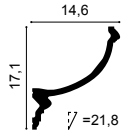

**C212**  
Purotouch®  
200 x 7,5 x 4,5 cm



**C201**  
Purotouch®  
200 x 11,6 x 4,8 cm

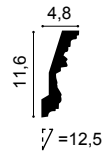

**C304**  
Purotouch®  
200 x 12,2 x 7,2 cm



**C303**  
Purotouch®  
200 x 14,4 x 6,5 cm



① **C219**  
Purotouch®  
200 x 17,6 x 13 cm

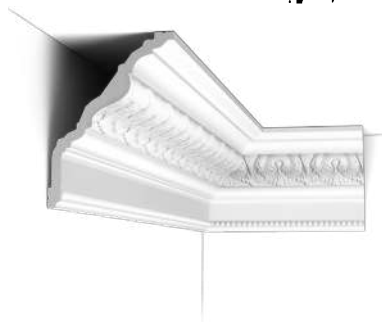
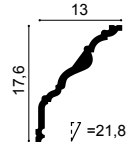

**C321 | C321F**  
Purotouch®  
200 x 9,9 x 5 cm

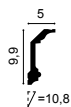

**C339 | C339F**  
Purotouch®  
200 x 14,1 x 6,4 cm

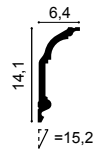

**C332 NOBLESSE**  
Purotouch®  
200 x 23 x 11,4 cm

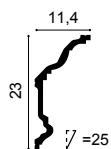

**C332 NOBLESSE** 90°  
Purotouch®  
200 x 11,4 x 23 cm

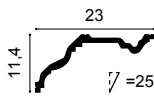

**C340**  
Purotouch®  
200 x 25,6 x 13,5 cm

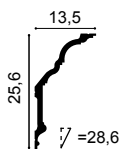

① **C340** 90°  
Purotouch®  
200 x 13,5 x 25,6 cm

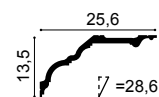

*the perfect finish*





**C250 | C250F**  
Purotouch®  
200 x 1,6 x 1,6 cm

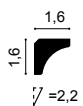

**C260**  
Purotouch®  
200 x 4,1 x 4,8 cm

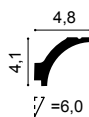

**C240 | C240F**  
Purotouch®  
200 x 8 x 8 cm

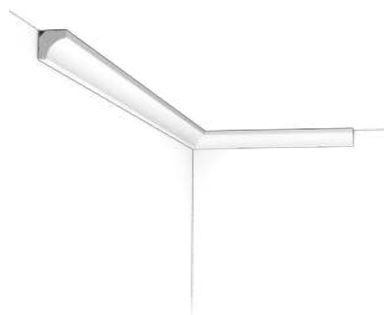
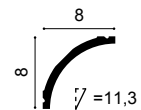

<sup>1</sup>-C990 + 2x CX188 p.150



Products

**C992 INFINITY** NEW  
 Purotouch®  
 200 x 7,7 x 10 cm



**C991 INFINITY**  
 Purotouch®  
 200 x 14 x 11 cm  
 Designed by Ulf Moritz

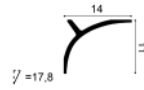

**C990 INFINITY**  
 Purotouch®  
 200 x 15,9 x 21,6 cm  
 Designed by Xavier Donck

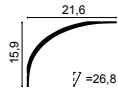

**C990 + P9900**

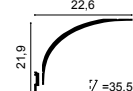

**C990 + 2x P9900**

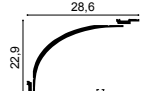

**C990 INFINITY** 90°  
 Purotouch®  
 200 x 21,6 x 15,9 cm  
 Designed by Xavier Donck

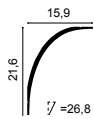

**C990 + P9900** 90°

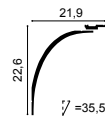

**C990 + 2x P9900** 90°

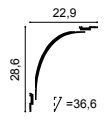

**C993 INFINITY** NEW  
 Purotouch®  
 200 x 23 x 31cm

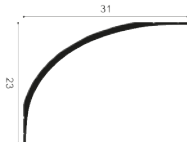

**C994 INFINITY** NEW  
 Purotouch®  
 200 x 30 x 40,5cm

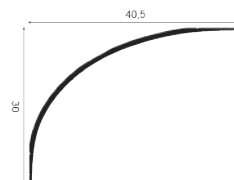



CORNICE MOULDINGS | KROONLIJSTEN | CORNICHES | STUCKLEISTEN | CORNISAS

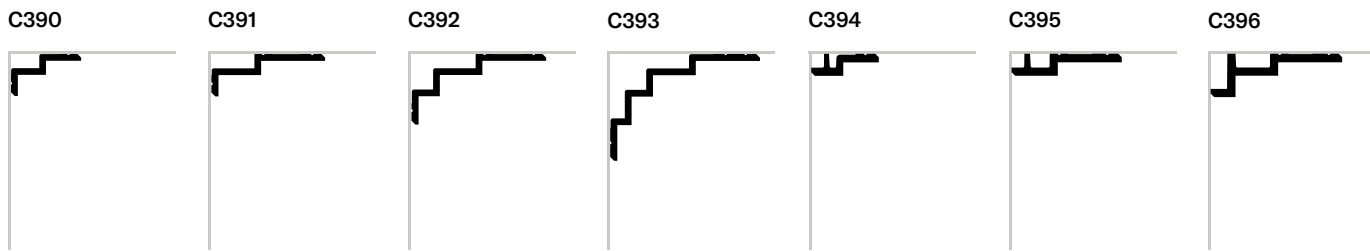

BORDER

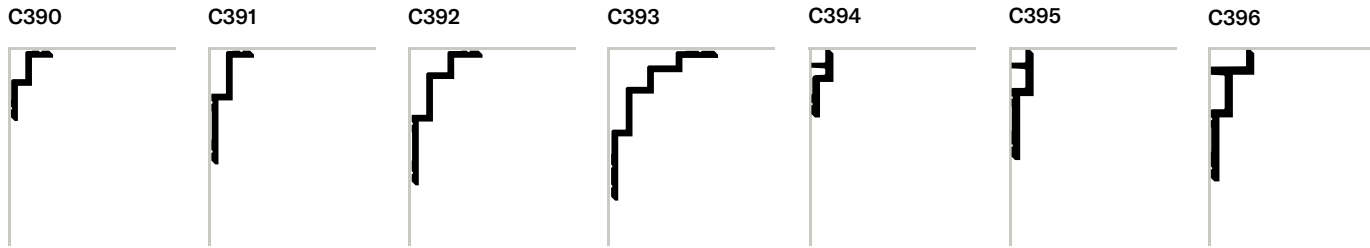

CURTAIN PROFILES | GORDIJNPROFIELEN | PROFILS RIDEAU | GARDINENLEISTEN | CORNISAS PARA CORTINAS

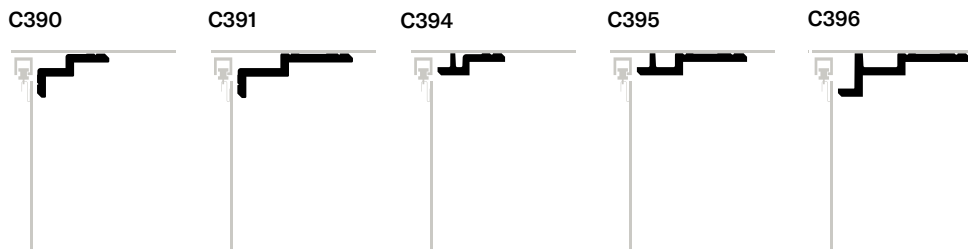

LED COVING | INDIRECTE VERLICHTING | ÉCLAIRAGE INDIRECT | INDIRECTE BELEUCHTUNG | ILUMINACIÓN INDIRECTA

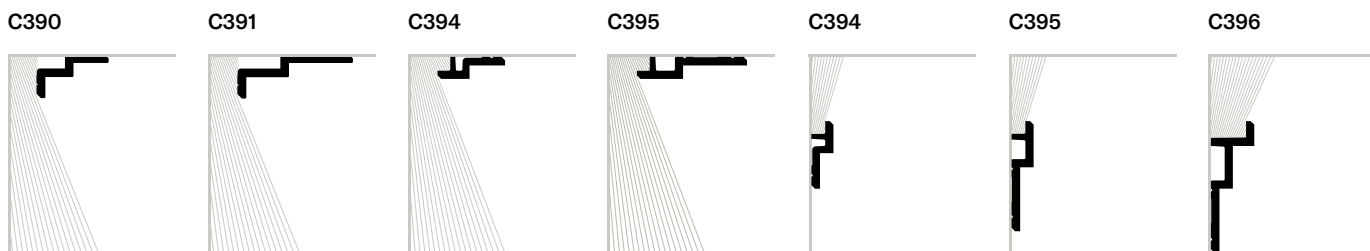

Downlighter

Uplighter

**C394 STEPS**  
Purotouch®  
200 x 9,5 x 3,1 cm  
Designed by Orio Tonini



**C395 STEPS**  
Purotouch®  
200 x 15,5 x 3,1 cm  
Designed by Orio Tonini



**C396 STEPS**  
Purotouch®  
200 x 18,5 x 6,1 cm  
Designed by Orio Tonini

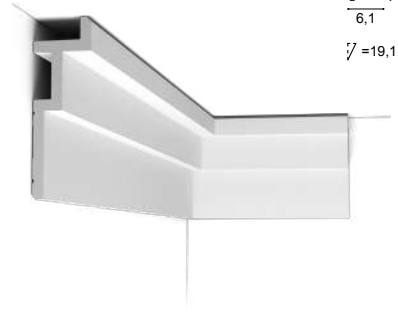
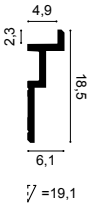

**C390 STEPS**  
Purotouch®  
200 x 6 x 10 cm  
Designed by Orio Tonini



① **C391 STEPS**  
Purotouch®  
200 x 6 x 16 cm  
Designed by Orio Tonini

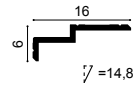

**C392 STEPS**  
Purotouch®  
200 x 10 x 19 cm  
Designed by Orio Tonini

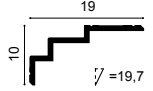

② **C393 STEPS**  
Purotouch®  
200 x 15 x 21 cm  
Designed by Orio Tonini

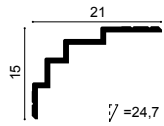

① C391 ② C393



**C360 MYLINE**  
Purotouch®  
200 x 2,1 x 6 cm  
Designed by Jacques Vergracht



**C356 MYLINE**  
Purotouch®  
200 x 2 x 10 cm  
Designed by Jacques Vergracht

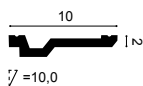

① **C355 MYLINE**  
Purotouch®  
200 x 3,5 x 11,1 cm  
Designed by Jacques Vergracht



**C353 MYLINE**  
Purotouch®  
200 x 3 x 16,5 cm  
Designed by Jacques Vergracht

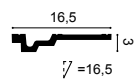

**C353 MYLINE** 90°  
Purotouch®  
200 x 3 x 16,5 cm  
Designed by Jacques Vergracht



**C354 MYLINE**  
Purotouch®  
200 x 4 x 21,5 cm  
Designed by Jacques Vergracht

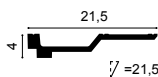

**C602**  
Purotouch®  
200 x 5,3 x 5 cm



**C400**  
Purotouch®  
200 x 6 x 10 cm





Cornice mouldings

1- C355 2- C991 p.77

# Curtain profiles

GORDIJNPROFIELEN  
PROFILS RIDEAU  
GARDINENLEISTEN  
CORNISAS PARA CORTINAS

ORAC



1. C340

**C394 STEPS  
CURTAIN PROFILE**  
Purotouch®  
200 x 3,1 x 9,5 cm  
Designed by Orio Tonini

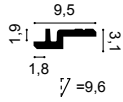

**C395 STEPS  
CURTAIN PROFILE**  
Purotouch®  
200 x 3,1 x 15,5 cm  
Designed by Orio Tonini

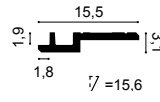

**C390 STEPS  
CURTAIN PROFILE**  
Purotouch®  
200 x 6 x 10 cm  
Designed by Orio Tonini

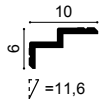

**C391 STEPS  
CURTAIN PROFILE**  
Purotouch®  
200 x 6 x 16 cm  
Designed by Orio Tonini

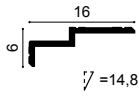

**C396 STEPS  
CURTAIN PROFILE**  
Purotouch®  
200 x 6,1 x 18,5 cm  
Designed by Orio Tonini

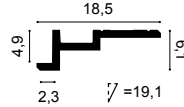

**C991  
CURTAIN PROFILE**  
Purotouch®  
200 x 11 x 14 cm  
Designed by Ulf Moritz

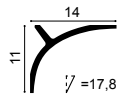

**C341 | C341F HERITAGE  
CURTAIN PROFILE**  
Purotouch®  
200 x 8,8 x 12,2 cm

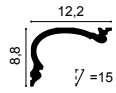

**C342 HERITAGE  
CURTAIN PROFILE**  
Purotouch®  
200 x 14 x 19 cm

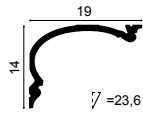

**C343 HERITAGE  
CURTAIN PROFILE**  
Purotouch®  
200 x 19 x 25 cm

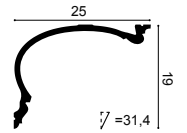

**C332 NOBLESSE  
CURTAIN PROFILE**  
Purotouch®  
200 x 11,4 x 23 cm

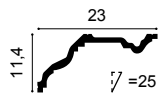

**C340  
CURTAIN PROFILE**  
Purotouch®  
200 x 13,5 x 25,6 cm

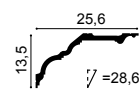

**CX196 U-STEPS  
CURTAIN PROFILE**

Duopolymer®  
200 x 4 x 11,3 cm

Designed by Orio Tonini



**CX197 U-STEPS  
CURTAIN PROFILE**

Duopolymer®  
200 x 5 x 9,3 cm

Designed by Orio Tonini



**CX215-2600 LEDGE (NEW)  
CURTAIN PROFILE**

Duopolymer®  
260 x 9,5 x 4,5 cm



**CX216-2600 LEDGE (NEW)  
CURTAIN PROFILE**

Duopolymer®  
260 x 12,5 x 4,5 cm



**CX217-2600 LEDGE (NEW)  
CURTAIN PROFILE**

Duopolymer®  
260 x 15,5 x 5 cm





1. CX215-2600

**CX124 | CX124F**  
Duropolymer®  
200 x 4,9 x 4,9 cm

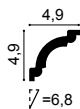

**CX100 | CX100F**  
Duropolymer®  
200 x 6,9 x 7,1 cm

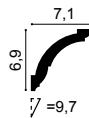

**CX123 | CX123F**  
Duropolymer®  
200 x 8 x 8 cm

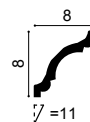

**CX127 | CX127F**  
Duropolymer®  
200 x 9,4 x 9,4 cm

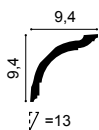

**CX199 | CX199F**  
Duropolymer®  
200 x 8 x 8 cm



**CX106 | CX106F**  
Duropolymer®  
200 x 11,8 x 11,7 cm

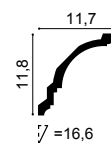

1 P8030 p.128 2 P8020 p.128 3 CX110

**CX203 | CX203F**  
Duropolymer®  
200 x 14,5 x 14,5 cm

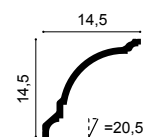

③ **CX111**  
Duopolymer®  
200 x 2,6 x 1,5 cm

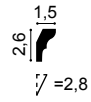

**CX110 | CX110F**  
Duopolymer®  
200 x 4,5 x 4,1 cm

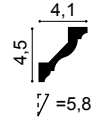

**CX108**  
Duopolymer®  
200 x 5,4 x 5,5 cm

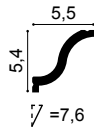

**CX112**  
Duopolymer®  
200 x 5,4 x 3,8 cm

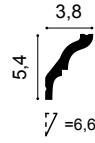

**CX177**  
Duopolymer®  
200 x 7 x 6 cm



**CX129**  
Duopolymer®  
200 x 9,4 x 9,4 cm

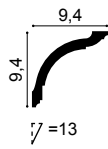

**CX107**  
Duopolymer®  
200 x 11,8 x 11,7 cm

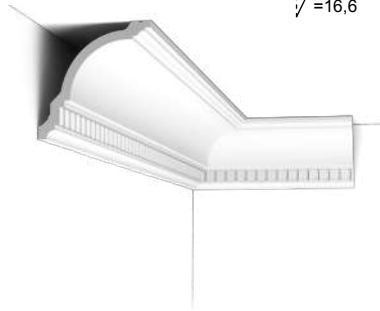
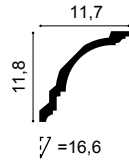

Cornice mouldings

*the perfect finish*



**CX133**  
Duopolymer®  
200 x 2 x 2 cm



**CX132**  
Duopolymer®  
200 x 2 x 2 cm



**CX115**  
Duopolymer®  
200 x 3 x 2,9 cm

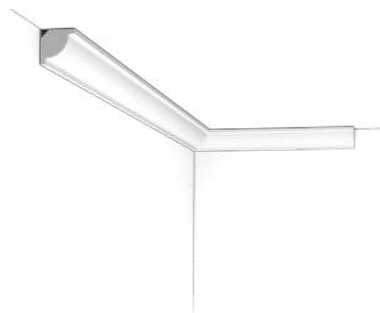

**CX109 | CX109F**  
Duopolymer®  
200 x 4,4 x 4,4 cm

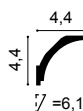

**CX126**  
Duopolymer®  
200 x 8,7 x 8,7 cm

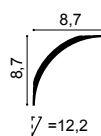

**CX148**  
Duopolymer®  
200 x 4,3 x 2,9 cm

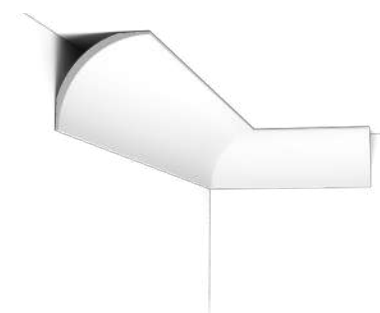
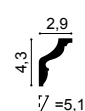

**CX141**  
Duopolymer®  
200 x 5,9 x 3,1 cm



**CX176**  
Duopolymer®  
200 x 8 x 4 cm

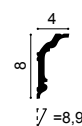

**CX192**  
Duopolymer®  
200 x 12 x 6 cm

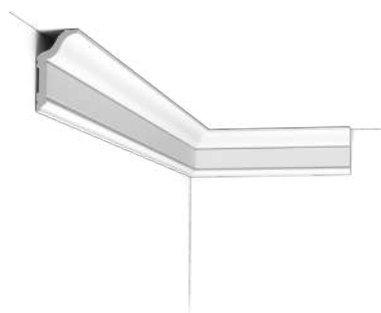
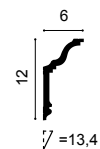

**CX215-2600 LEDGE** (NEW)  
Duopolymer®  
260 x 9,5 x 4,5 cm



**CX216-2600 LEDGE** (NEW)  
Duopolymer®  
260 x 12,5 x 4,5 cm



**CX217-2600 LEDGE** (NEW)  
Duopolymer®  
260 x 15,5 x 5 cm

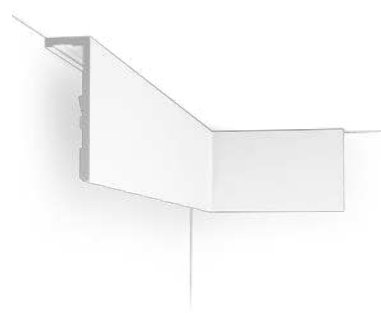

Products

① **CX190 | CX190F** U-PROFILE  
 Duropolymer®  
 200 x 2 x 3 cm  
 Designed by Orio Tonini



**CX196** U-STEPS  
 Duropolymer®  
 200 x 11,3 x 4 cm  
 Designed by Orio Tonini

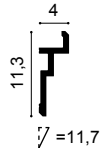

**CX197** U-STEPS  
 Duropolymer®  
 200 x 9,3 x 5 cm  
 Designed by Orio Tonini

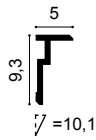

② **PX198 | PX198F** U-STEPS  
 Duropolymer®  
 200 x 8,3 x 2 cm  
 Designed by Orio Tonini



**PX198 | PX198F** U-STEPS 90°  
 Duropolymer®  
 200 x 2 x 8,3 cm  
 Designed by Orio Tonini



Cornice mouldings

1. CX190F 2. PX198F 3. W111F p.103 4. W116F p.103 5. W119F p.103

1. CX192 p.88 2. P8030 p.128



②

①

**SX194 | SX194F** SQUARE  
Duropolymer®  
200 x 1 x 2 cm



**SX162 | SX162F** SQUARE  
Duropolymer®  
200 x 1 x 4 cm



**SX157 | SX157F** SQUARE  
Duropolymer®  
200 x 1,3 x 6,5 cm



**SX163 | SX163F** SQUARE  
Duropolymer®  
200 x 1,3 x 10,1 cm

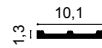

**SX182 | SX182F** CASCADE  
Duropolymer®  
200 x 1,3 x 5 cm



**SX183 | SX183F** CASCADE  
Duropolymer®  
200 x 1,3 x 7,5 cm

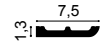

**SX184 | SX184F** CASCADE  
Duropolymer®  
200 x 1,3 x 11 cm

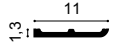

**CX160**  
Duropolymer®  
200 x 1,3 x 3,9 cm



**CX161**  
Duropolymer®  
200 x 1,3 x 6,9 cm

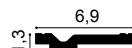

*the perfect finish*



**CB500N**  
Durofoam®  
200 x 2,5 x 1,8 cm

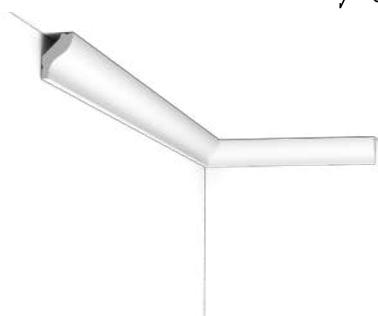
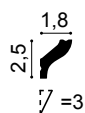

**CB501N**  
Durofoam®  
200 x 4,1 x 3,5 cm

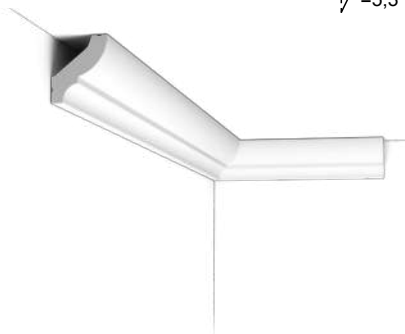
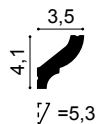

**CB502N**  
Durofoam®  
200 x 5,9 x 4,9 cm

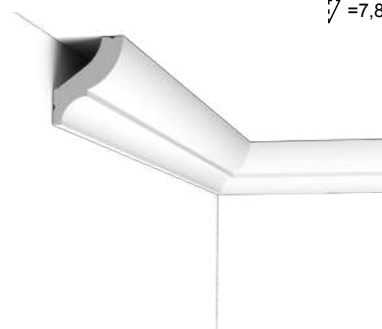

**CB520N**  
Durofoam®  
200 x 3,5 x 3,5 cm

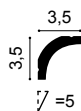

**CB521N**  
Durofoam®  
200 x 5 x 5 cm

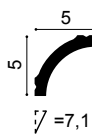

**CB522N**  
Durofoam®  
200 x 6,7 x 6,7 cm

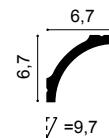

**CB525N**  
Durofoam®  
200 x 6,5 x 6 cm

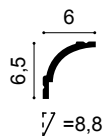

**CB523N**  
Durofoam®  
200 x 5,9 x 4,4 cm

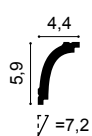

**CB510N**  
Durofoam®  
200 x 4 x 4 cm

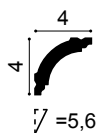

**CB511N**  
Durofoam®  
200 x 6,7 x 6,7 cm

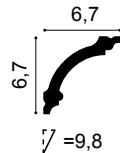

① **CB512N**  
Durofoam®  
200 x 9 x 9 cm

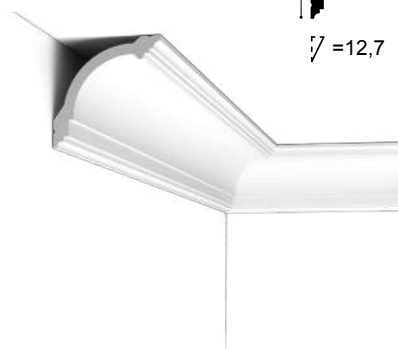
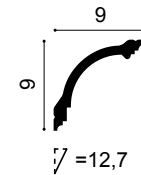

**CB503N**  
Durofoam®  
200 x 8,2 x 9,2 cm

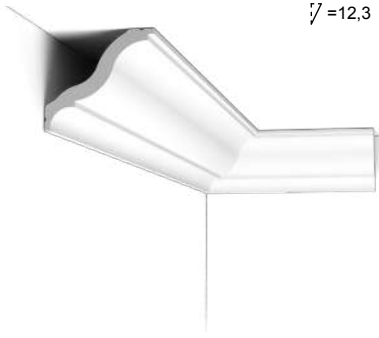
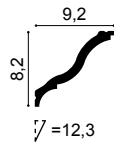

**CB524N**  
Durofoam®  
200 x 9 x 9 cm

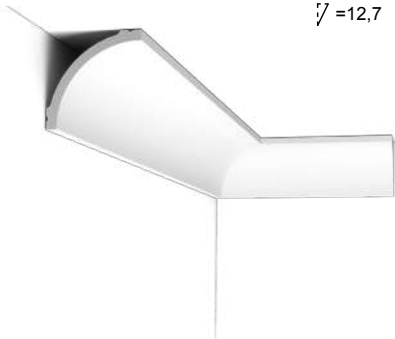
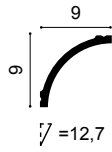

<sup>1</sup> CB512N <sup>2</sup> PX103 p.135

# 3D Wall covering

02

3D WANDBEKLEDING  
REVÊTEMENTS MURAUX 3D  
3D WANDVERTÄFELUNG  
REVESTIMIENTO DE PARED 3D

We invite you to experience the extraordinary with our 3D wall coverings. Captivating sculptural landscapes, these masterpieces redefine your walls, inviting touch and exploration. Discover a range of bold and subtle designs, each a testament to the art of interior transformation.

3D Wall covering

**NL —**

Laat je verrassen door het ongeken-  
de met onze 3D wandbekleding.  
Adembenemende sculpturen die  
uw muren tot een nieuw leven  
wekken, uitnodigend tot aanraken en  
verkennen. Duik in een assortiment  
van gedurfde en subtiele ontwerpen,  
die stuk voor stuk blijk geven  
van de vernieuwende impact op  
interieurdesign.

**FR —**

Faites l'expérience de l'extraordinaire  
avec nos revêtements muraux  
3D si vous le souhaitez. Des  
paysages sculpturaux captivants.  
Ces chefs-d'œuvre redéfinissent  
vos murs, invitant au toucher et à  
l'exploration. Découvrez une gamme  
de designs audacieux et subtils,  
chacun témoignant de l'art de la  
transformation intérieure.

**DE —**

Erleben Sie das Außergewöhnliche  
mit unseren 3D-Wandverkleidungen.  
Fesselnde skulpturale Landschaften.  
Diese Meisterwerke definieren Ihre  
Wände neu und laden zum Anfassen  
und Erforschen ein. Entdecken  
Sie eine Reihe kühner und subtiler  
Entwürfe, von denen jeder ein Zeugnis  
für die Kunst der Innenraumumge-  
staltung ist.

**ES —**

Experimenta lo extraordinario con  
nuestros revestimientos de pared 3D.  
Paisajes esculturales y cautivadores.  
Estas obras maestras redefinen  
tus paredes, invitando al tacto y la  
exploración. Descubre una variedad  
de diseños audaces y sutiles, cada uno  
siendo un testimonio del arte de la  
transformación interior.

100% plant-based & recycled

# — Where art meets science

Duropolymer isn't new to us, but our method is. We have been making profound changes in the full lifecycle of this product. We are combining plant-based materials with recycled elements to create sustainable masterpieces. And we've got the ISCC certification\* to prove it (for the plant-based share).



**PLANT-BASED  
MATERIALS WITH  
ISCC CERTIFICATION**



**RECYCLED  
POST-CONSUMER AND  
POST-INDUSTRIAL WASTE**

NL —

Duropolymer is niet nieuw voor ons, maar onze methode is dat wel. We hebben ingrijpende veranderingen aangebracht in de volledige levenscyclus van dit product. We combineren plant-based grondstoffen met gerecyclede elementen om duurzame meesterwerken te creëren. En we hebben de ISCC-certificering\* voor het biobased aandeel om het te bewijzen. Dit nieuwe tijdperk van milieubewuste decoratie is waar kunst wetenschap ontmoet.

FR —

Le duropolymer n'est pas une nouveauté pour nous, mais notre nouvelle méthode l'est. Nous avons fait des changements profonds dans le cycle de vie complet de ce produit. Nous combinons des matériaux d'origine végétale et recyclés pour créer des solutions durables. Et nous avons la certification ISCC\* pour le prouver. Cette nouvelle ère de décoration éco-responsable est là où l'art rencontre la science.

DE —

Duropolymer ist für uns nicht neu, aber unsere neue Methode ist es. Wir haben den gesamten Lebenszyklus dieses Produkts grundlegend verändert. Wir kombinieren pflanzliche und recycelte Elementen, um nachhaltige Meisterwerke zu schaffen. Um dies zu belegen, haben wir die ISCC-Zertifizierung\* für den biobasierten Anteil. In dieser neuen Ära des umweltbewussten Dekors trifft Kunst auf Wissenschaft.

ES —

El duropolymer no es nuevo para nosotros, pero sí lo es nuestro nuevo método. Hemos estado haciendo cambios significativos en el ciclo de vida completo de este producto. Combinamos materiales de origen vegetal y reciclados para crear obras maestras sostenibles para crear esta obra maestra sostenible. Y tenemos la certificación ISCC\* para la parte de origen biológica para demostrarlo. Esta nueva era de diseño ecológico es donde el arte se encuentra con la ciencia.

**WX204 | WX204-2600 RIPPLE**

Duopolymer®  
200 x 25 x 1,6 cm  
260 x 25 x 1,6 cm

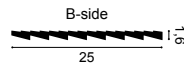
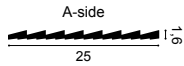

**WX205 | WX205-2600 | WX205F TRACK**

Duopolymer®  
200 x 25 x 1,3 cm  
260 x 25 x 1,3 cm

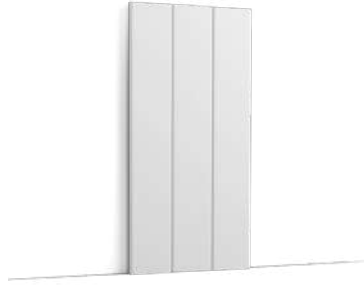
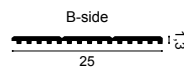
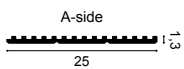

① **WX210 | WX210-2600 | WX210F REED**

Duopolymer®  
200 x 25,5 x 1,2 cm  
260 x 25,5 x 1,2 cm

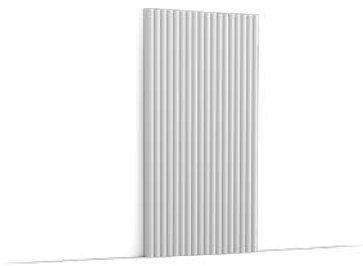

② **WX211 | WX211-2600 | WX211F FLUTE**

Duopolymer®  
200 x 25,5 x 1,7 cm  
260 x 25,5 x 1,7 cm

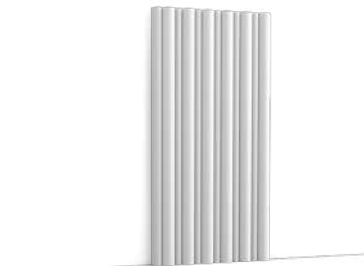

**WX218 | WX218-2600 | WX218F FLUTE.XL** NEW

Duopolymer®  
200 x 25,5 x 1,7 cm  
260 x 25,5 x 1,7 cm

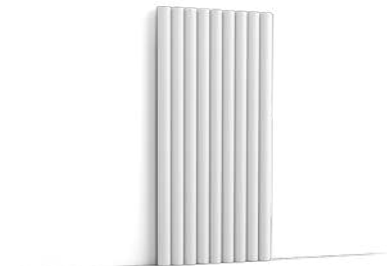
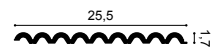

**WX213 | WX213-2600 | WX213F ALTO** NEW

Duopolymer®  
200 x 25 x 1,2 cm  
260 x 25 x 1,2 cm

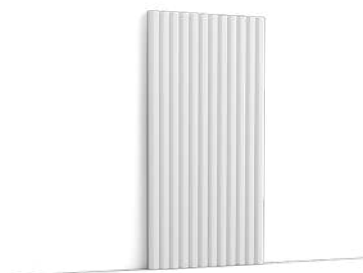
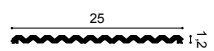

**SX207 | SX207F SQUARE**

Duopolymer®  
200 x 25 x 1,3 cm



1. WX210 2. WX211

**W108 | W108-2600 | W108F ZIGZAG**

Purotouch®  
200 x 25 x 1,8 cm  
260 x 25 x 1,8 cm

Designed by Orio Tonini

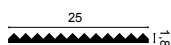

**W108 ZIGZAG + 2x CX190**



⑤ **W110 | W110-2600 | W110F HILL**

Purotouch®  
200 x 25 x 1,6 cm  
260 x 25 x 1,6 cm

Designed by Orio Tonini

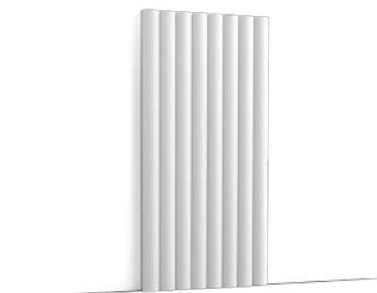
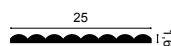

**W110 HILL + 2x CX190**



② **W213 HILL TRACE**

Purotouch®  
200 x 25 x 1,6 cm

Designed by Orio Tonini

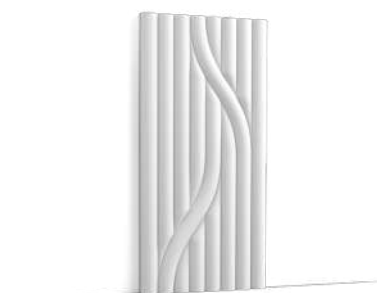
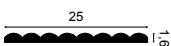

**W214 | W214F HILL BEAD XL**

Purotouch®  
200 x 40 x 1,5 cm

Designed by Orio Tonini

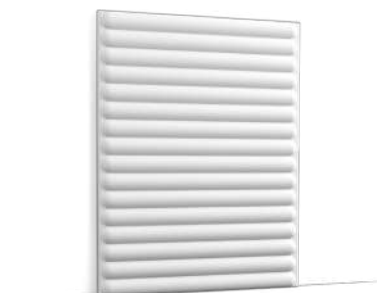
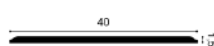

**W215 HILL BEAD**

Purotouch®  
50 x 80 x 1,5 cm

Designed by Orio Tonini





3D Wall covering

1. PX209 p.137 2. W213 3. WX210 p.97 4. WX211 p.97 5. W110 6. CX190 p.122



1. W109 2. PX209 p.137 3. W212

① W109 | W109-2600 | W109F VALLEY

Purotouch®  
200 x 25 x 1,2 cm  
260 x 25 x 1,2 cm  
Designed by Orio Tonini

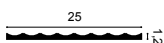

W114 | W114-2600 | W114F VALLEY XL

Purotouch®  
200 x 25 x 1,5 cm  
260 x 25 x 1,5 cm  
Designed by Orio Tonini

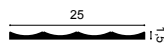

③ W212 VALLEY LOOP

Purotouch®  
200 x 25 x 1,2 cm  
Designed by Orio Tonini

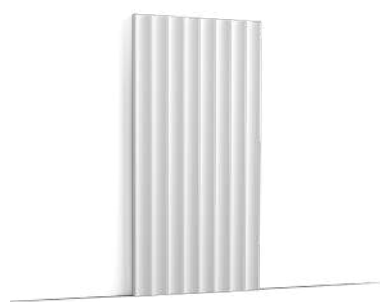
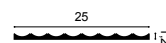

W109 VALLEY + 2x CX190

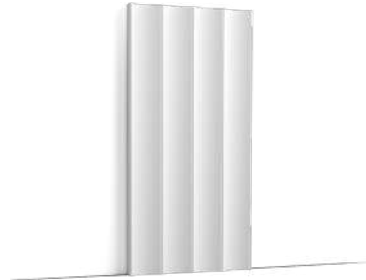

W114 VALLEY XL + 2x SX194

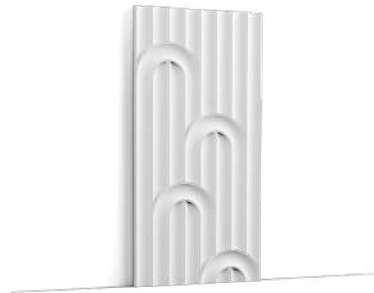

③ W212 VALLEY LOOP + 2x PX209



⑥ **W217** PILLOW  
Purotouch®  
200 x 25 x 2,3 cm  
Designed by Orio Tonini

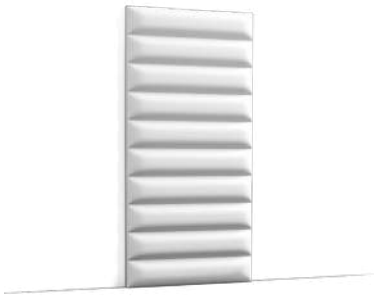
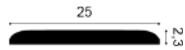

④ ⑥ **W217** PILLOW + **SX182**



⑤ **W218** QUILT  
Purotouch®  
200 x 25 x 2,3 cm  
Designed by Orio Tonini

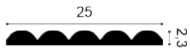

⑤ ⑥ **W218** QUILT + **SX182**



2. **PX209** p.137 4. **W217** 5. **W218** 6. **SX182** p.137



3D Wall covering

# — Beyond surface beauty

## ACOUSTIC CONTRIBUTION — CLASS E

In combination with other elements, Purotouch has a positive effect on the overall sound quality, absorbing up to 25% of conversational sounds.

## THERMAL COMFORT

Purotouch offers thermal insulation comparable to that of specialized insulation boards of equal thickness.

$\lambda = 0,029 \text{ W/mK}$

## ECO-CONSCIOUS FROM MATERIAL TO FINISH

Over 11% of Purotouch's composition is biobased, sourced from sugar beet and sugar cane. Additionally, we apply a primer paint that contains 14% biobased content.

### NL –

#### AKOESTISCHE BIJDRAGE - KLASSE E

Purotouch heeft, in combinatie met andere elementen in de ruimte, een positief akoestisch effect, en absorbeert tot 25% van een gesprek.

#### THERMISCH COMFORT

Purotouch biedt een thermische isolatie die vergelijkbaar is met die van gespecialiseerde isolatieplaten van gelijke dikte.  $\lambda = 0,029 \text{ W/mK}$

#### MILIEUBEWUST VAN MATERIAAL TOT AFWERKING

Meer dan 11% van de samenstelling van Purotouch is biobased, afkomstig van suikerbieten en suikerriet. Bovendien gebruiken we een grondverf waarvan 14% biobased is.

### FR –

#### CONTRIBUTION ACOUSTIQUE - CLASSE E

En combinaison avec d'autres éléments, Purotouch a un effet positif sur la qualité sonore globale en absorbant jusqu'à 25% des bruits de conversation.

#### CONFORT THERMIQUE

Purotouch offre une isolation thermique équivalente à celle de panneaux isolants spécialisés de même épaisseur.  $\lambda = 0,029 \text{ W/mK}$

#### ÉCO-CONSCIENT DU MATÉRIAU À LA FINITION

Plus de 11% de la composition de Purotouch est biosourcée, à partir de betterave et de canne à sucre. Nous utilisons également une peinture primaire contenant 14% de composants biosourcés.

### DE –

#### AKUSTISCHER BEITRAG - KLASSE E

In Kombination mit anderen Elementen hat Purotouch einen positiven Effekt auf die Gesamtklangqualität und absorbiert bis zu 25% des Raumschalls.

#### THERMISCHER KOMFORT

Purotouch bietet eine Wärmedämmung, die mit der von speziellen Dämmplatten gleicher Dicke vergleichbar ist.  $\lambda = 0,029 \text{ W/mK}$

#### UMWELTBEWUST VOM MATERIAL BIS ZUR VERARBEITUNG

Über 11% der Zusammensetzung von Purotouch ist biobasiert und wird aus Zuckerrüben und Zuckerrohr gewonnen. Außerdem verwenden wir eine Grundierung, die zu 14% aus biobasierten Rohstoffen besteht.

### ES –

#### CONTRIBUCIÓN ACÚSTICA - CLASE E

En combinación con otros elementos, nuestros productos Purotouch tienen un efecto positivo en la calidad general del sonido, absorbiendo hasta un 25% de los sonidos de conversación.

#### CONFORT TÉRMICO

Purotouch ofrece un aislamiento térmico comparable al de los paneles aislantes especializados de igual grosor.  $\lambda = 0,029 \text{ W/mK}$

#### CONCIENCIA ECOLÓGICA DESDE EL MATERIAL HASTA EL ACABADO

Más del 11% de la composición de Purotouch es de base biológica, procedente de la remolacha azucarera y la caña de azúcar. Además, aplicamos una pintura de imprimación que contiene un 14% de biobasura.



1. W116 2. W111 3. W119 4. CX190 p.122

3D Wall covering

② W111 | W111-2600 | W111F BAR

Purotouch®  
200 x 25 x 2 cm  
260 x 25 x 2 cm  
Designed by Orio Tonini

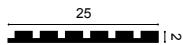

① W116 | W116-2600 | W116F BAR XL

Purotouch®  
200 x 25 x 2 cm  
Designed by Orio Tonini

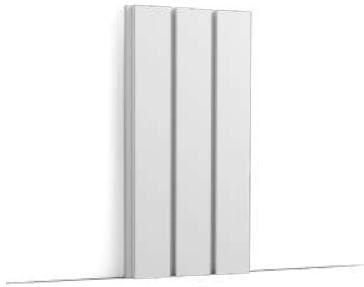
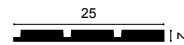

③ W119 | W119-2600 | W119F BAR MIX

Purotouch®  
200 x 25 x 2 cm  
Designed by Orio Tonini

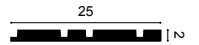

② ④ W111 BAR + CX190 + PX198



① ④ W116 BAR XL + CX190 + PX198



③ ④ W119 BAR MIX + CX190 + PX198



**W115 SLOPE**

Purotouch®  
200 x 25 x 2,3 cm  
Designed by Orio Tonini

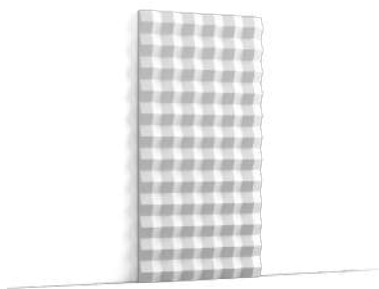
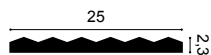

① **W216 MATRIX**

Purotouch®  
200 x 25 x 1,6 cm  
Designed by Orio Tonini

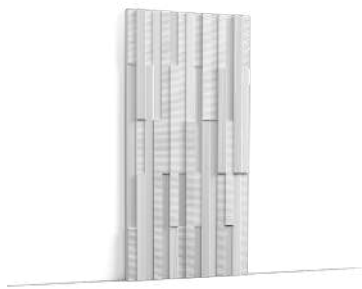
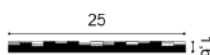

**W219 ZEA** NEW

Purotouch®  
200 x 25 x 1,9 cm  
Designed by Jan Erika

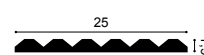

① **W216**



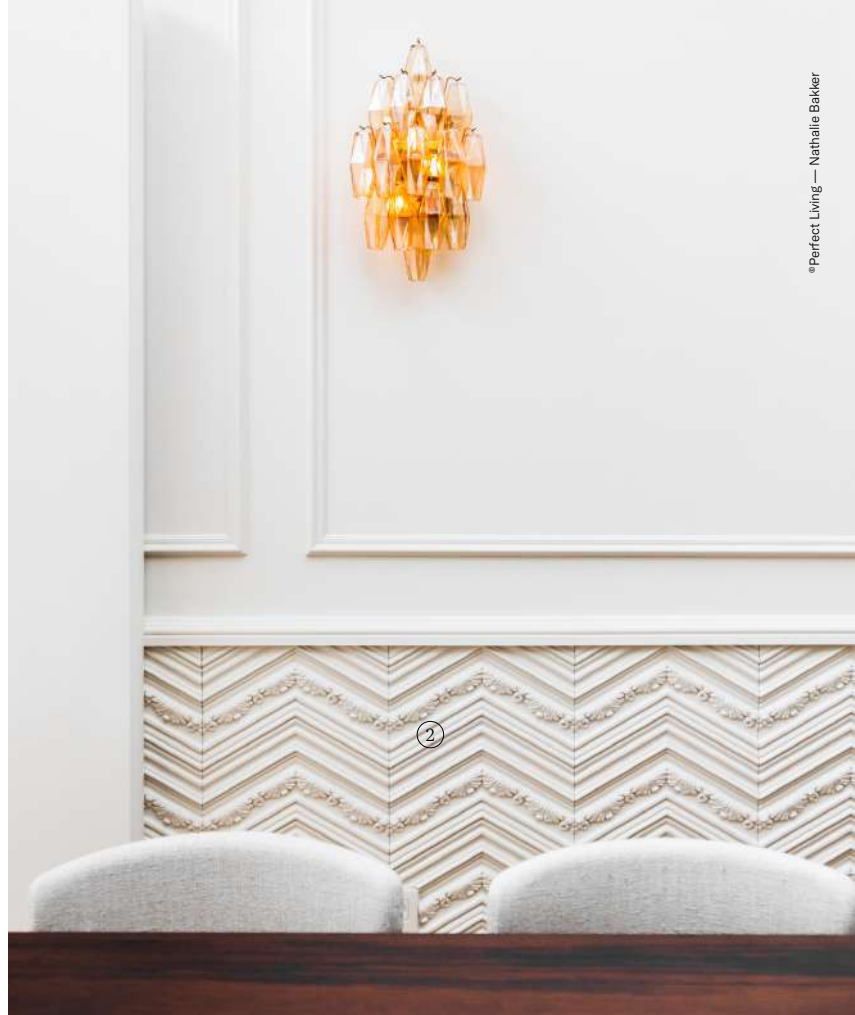

2. W130

**W112 RIDGE**  
Purotouch®  
200 x 25 x 1,9 cm  
Designed by Orio Tonini

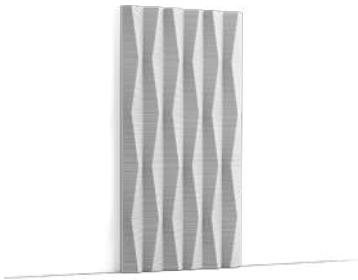
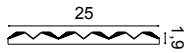

**W113 COBBLE**  
Purotouch®  
200 x 25 x 2,2 cm  
Designed by Orio Tonini

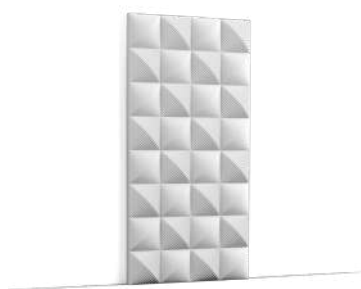
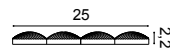

② **W130 CHEVRON**  
Purotouch®  
200 x 40 x 2 cm

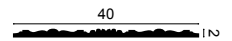

**W112 RIDGE + 2x CX190**

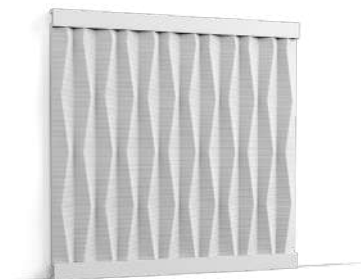

**W113 COBBLE + 2x CX190**

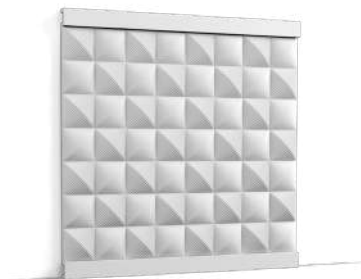

**W130 CHEVRON + 2x CX190**

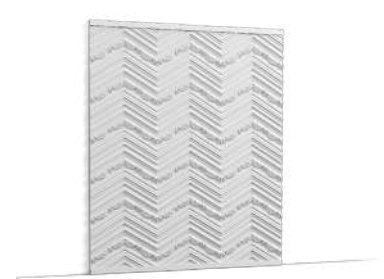

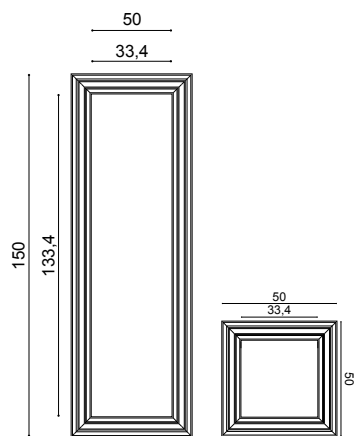

**W120 + P4025 + W121**  
Purotouch®  
Designed by Orio Tonini

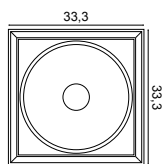
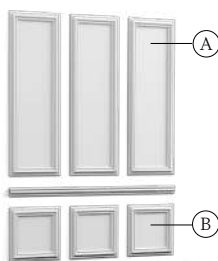

**W122 AUTOIRE**  
Purotouch®  
33,3 x 33,3 x 2,6 cm  
Designed by Orio Tonini

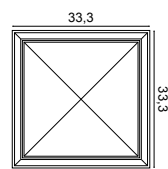

**W123 AUTOIRE**  
Purotouch®  
33,3 x 33,3 x 3,5 cm  
Designed by Orio Tonini



③ **W120 AUTOIRE**  
Purotouch®  
50 x 150 x 3,2 cm  
Designed by Orio Tonini



**W120 + 4\*W122**  
Purotouch®  
Designed by Orio Tonini

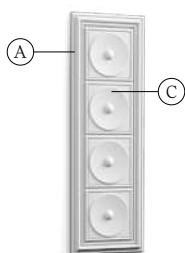

**W120 + 4\*W123**  
Purotouch®  
Designed by Orio Tonini

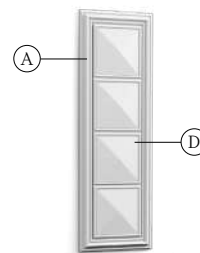

④ **W121 AUTOIRE**  
Purotouch®  
50 x 50 x 3,2 cm  
Designed by Orio Tonini



**W121 + W122**  
Purotouch®  
Designed by Orio Tonini

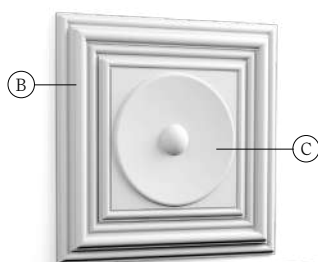

**W121 + W123**  
Purotouch®  
Designed by Orio Tonini

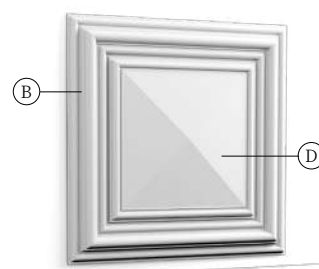

1. DX170-2600 p.162 2. D330LR p.162 3. W120 4. W121 5. SX138 p.117



3D Wall covering



1. W125 2. W125A 3. P9903 p.132 4. SX181 p.118

**W124 BURLINGTON**

Purotouch®

80 x 50 x 2,2 cm

Designed by Orio Tonini



① **W125 SWIRL** **NEW**

Purotouch®

80 x 50 x 1,7cm

Designed by Roelfien Vos



② **W125A** **NEW**

Purotouch®

ø 11,6 x 0,7 cm

Designed by Roelfien Vos



**W125 + W125 A** **NEW**

Purotouch®

80 x 50 x 1,7cm

Designed by Roelfien Vos



**W126 CHAIN** **NEW**

Purotouch®

80 x 50 x 3,5cm

Designed by Roelfien Vos

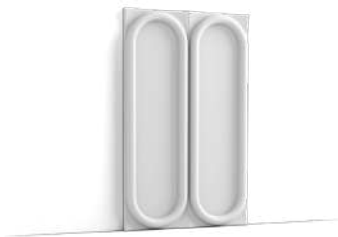

**W100 ROMBUS**  
Purotouch®  
25,8 x 15 x 2,9 cm

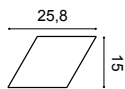

**W101 TRAPEZIUM**  
Purotouch®  
34,5 x 15 x 2,9 cm

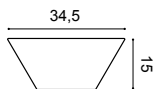

**W105 ROMBUS**  
Purotouch®  
30 x 34,6 x 3 cm

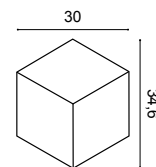

1. W106 2. W107



① **W106 ENVELOP**  
Purotouch®  
33,3 x 33,3 x 2,9 cm  
*Designed by Orio Tonini*

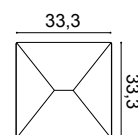

② **W107 CIRCLE**  
Purotouch®  
33,3 x 33,3 x 2,9 cm  
*Designed by Orio Tonini*

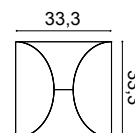

# Ceiling ornaments

1. F30



3D Wall covering

**F30**  
Purotouch®  
59,5 x 59,5 x 4,3 cm

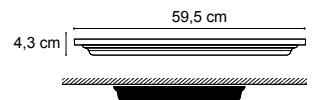



# Skirting boards

03



PLINTEN  
PLINTHES  
SOCKELLEISTEN  
ZÓCALOS

Crafting seamless transitions from floor to wall, from the elegantly ornate to the gracefully understated. We pay meticulous attention to every detail in every design so you can find options that match your vision.

**NL —**  
Een naadloze overgang van vloer tot muur. Van elegant sierlijk tot sierlijk ingetogen. Elk detail goed doordacht uitgewerkt om altijd een optie te vinden die bij je past.

**FR —**  
La création de transitions harmonieuses entre le sol et la surface, de l'élégamment orné au gracieusement discret. Nous accordons une attention méticuleuse aux détails dans chaque conception, afin que vous puissiez trouver les options qui correspondent à votre vision.

**DE —**  
Wir schaffen nahtlose Übergänge vom Boden zur Wand. Von elegant verziert bis hin zu anmutig schlicht. Wir legen bei jedem Entwurf besonderen Wert auf die Details, damit Sie die Möglichkeiten finden, die Ihre Visionen wahr werden lassen.

**ES —**  
Transiciones perfectas del suelo a la pared, delo suntuosamente ornamentado hasta lo sutilmente sofisticado. Prestamos una meticulosa atención a los detalles en cada diseño, para que encuentres opciones que se ajusten a tu visión.

# Three cornerstone skirting families

They invite  
you to create.

**NL —**  
**Drie basis plintfamilies**  
Ze nodigen je uit om te creëren

**FR —**  
**Trois familles de plinthes clés**  
Une invitation à la créativité

**DE —**  
**Drei Sockel-Designfamilien  
als Eckpfeiler**  
Sie laden Sie ein, etwas zu erschaffen

**ES —**  
**Tres familias de zócalos  
fundamentales**  
Te invitan a crear



1. SX118 2. PX103 p.135

small

medium

large

Skirting boards

cover

**SX162 | SX162F |  
SX162-RAL9003 SQUARE**  
Duropolymer®  
200 x 4 x 1 cm

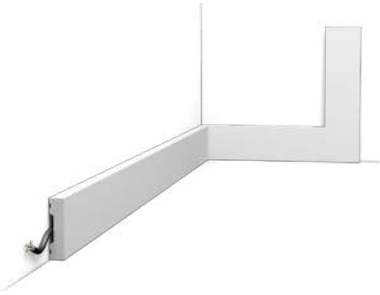

**SX182 | SX182F CASCADE**  
Duropolymer®  
200 x 5 x 1,3 cm

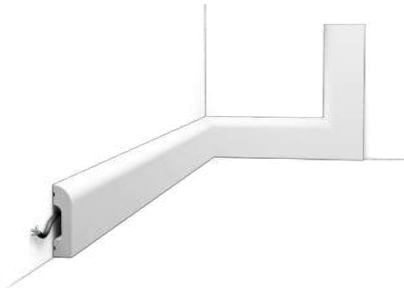

**SX165 | SX165F CONTOUR**  
Duropolymer®  
200 x 6,9 x 1,1 cm

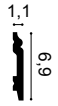

**SX157 | SX157F |  
SX157-RAL9003 SQUARE**  
Duropolymer®  
200 x 6,5 x 1,3 cm

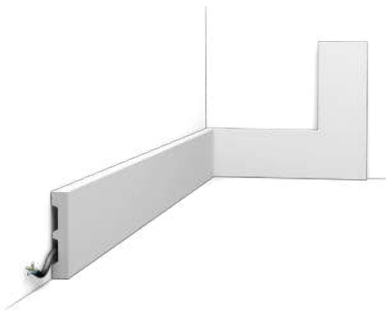

**SX183 | SX183F |  
SX183-RAL9003 CASCADE**  
Duropolymer®  
200 x 7,5 x 1,3 cm

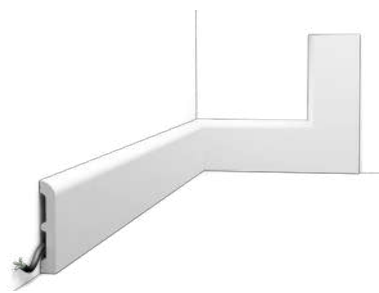

**SX173 | SX173F |  
SX173-RAL9003 CONTOUR**  
Duropolymer®  
200 x 10 x 1,6 cm

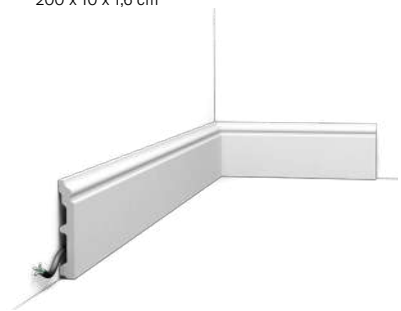
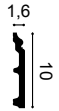

**SX163 | SX163F |  
SX163-RAL9003 SQUARE**  
Duropolymer®  
200 x 10,1 x 1,3 cm

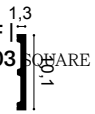

**SX184 | SX184F |  
SX184-RAL9003 CASCADE**  
Duropolymer®  
200 x 11 x 1,3 cm

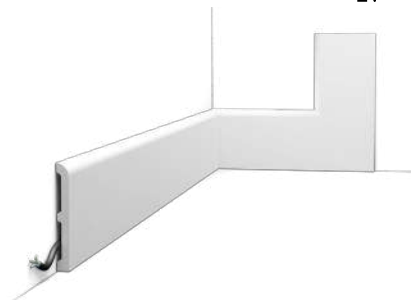
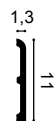

**SX118 | SX118F |  
SX118-RAL9003 CONTOUR**  
Duropolymer®  
200 x 13,9 x 1,8 cm



**SX171 | SX171-RAL9003 SQUARE**  
Duropolymer®  
200 x 10 x 2,2 cm



**SX185 CASCADE**  
Duropolymer®  
200 x 12 x 2,5 cm

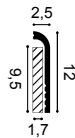

**SX186 CONTOUR**  
Duropolymer®  
200 x 13,8 x 2,2 cm

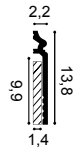

Square

Cascade

Contour

**SX195 | SX195F HAMBURG**  
 Duopolymer®  
 200 x 8 x 1,9 cm



**SX105 | SX105F**  
 Duopolymer®  
 200 x 11 x 1,3 cm

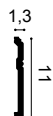

**④ SX155 | SX155F**  
 Duopolymer®  
 200 x 10,8 x 2,5 cm

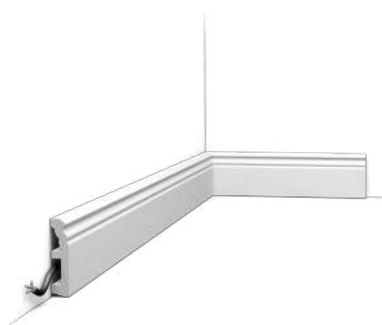

<sup>1</sup> DX170-2600 p.162   <sup>2</sup> P9010 p.128   <sup>3</sup> P9050 p.130   <sup>4</sup> SX155





**SX137 | SX137F**  
Duropolymer®  
200 x 10 x 1,5 cm



1. **W120** p.106 2. **W121** p.106 3. **W122** p.106 4. **W123** p.106 5. **P4025** p.128 6. **SX138** p.117

**SX138 | SX138F**  
Duropolymer®  
200 x 13,8 x 1,5 cm



**SX206 CONTOUR**  
Duropolymer®  
200 x 18 x 1,8 cm

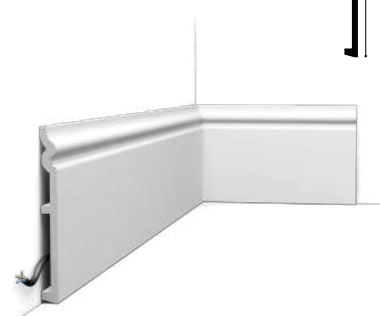

**SX193 AUTOIRE**  
Duropolymer®  
200 x 25 x 2,2 cm  
*Designed by Orio Tonini*



**SX187 | SX187F HIGH LINE**

Duropolymer®

200 x 7,5 x 1,2 cm

Designed by Pierre Daems

**② SX180 | SX180F HIGH LINE**

Duropolymer®

200 x 12 x 1,6 cm

Designed by Pierre Daems

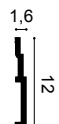
**SX181 HIGH LINE**

Duropolymer®

200 x 20 x 2,2 cm

Designed by Pierre Daems

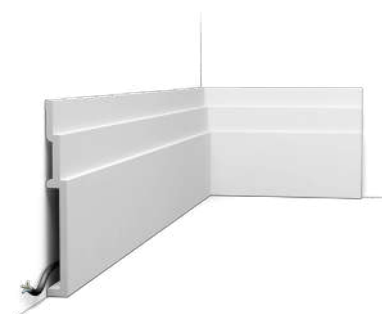

<sup>1</sup> P7070 p.130    <sup>2</sup> SX180





Skirting boards

3. W120 p.106 4. W121 p.106 5. SX191

**SX104 | SX104F**  
Duropolymer®  
200 x 15 x 1,8 cm

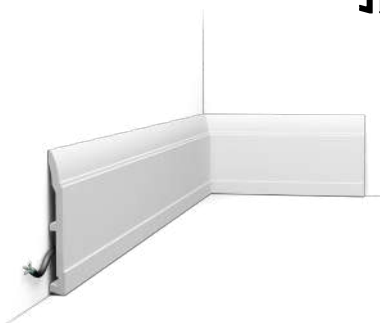
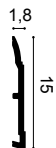

**SX156 HIGH HEELS**  
Duropolymer®  
200 x 20,2 x 1,6 cm  
*Designed by Xavier Donck*



⑤ **SX191 HIGH RISE**  
Duropolymer®  
200 x 21 x 2,1 cm

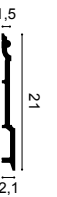

**SX194 | SX194F SQUARE**  
Duopolymer®  
200 x 2 x 1 cm

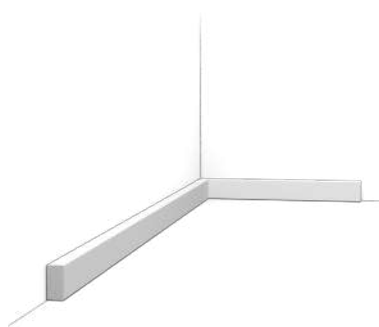

**CX132**  
Duopolymer®  
200 x 2 x 2 cm

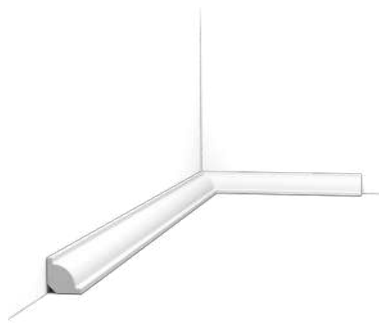

**CX133**  
Duopolymer®  
200 x 2 x 2 cm

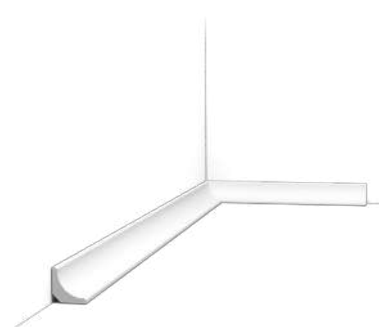

③ **CX190 | CX190F U-PROFILE**  
Duopolymer®  
200 x 3 x 2 cm  
*Designed by Orio Tonini*

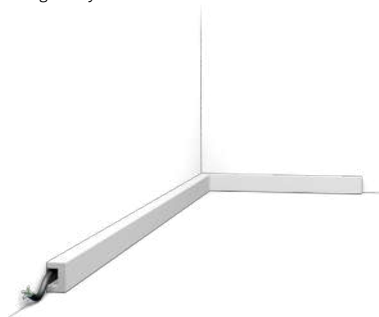

**PX198 | PX198F U-STEPS**  
Duopolymer®  
200 x 8,3 x 2 cm  
*Designed by Orio Tonini*



**PX198 | PX198F U-STEPS** 180°  
Duopolymer®  
200 x 8,3 x 2 cm  
*Designed by Orio Tonini*



**SX159**  
Duopolymer®  
200 x 6 x 1,2 cm

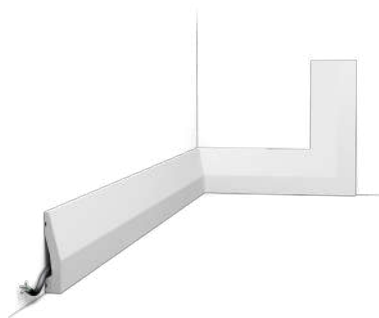

**SX125**  
Duopolymer®  
200 x 6,9 x 1,4 cm



**SX179 DIAGONAL**  
Duopolymer®  
200 x 9,7 x 2,9 cm  
*Designed by Orio Tonini*

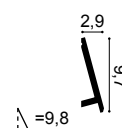

**SX172 | SX172F**  
Duopolymer®  
200 x 8,5 x 1,4 cm



<sup>1</sup> C343 p.66   <sup>2</sup> P8020 p.128   <sup>3</sup> CX190   <sup>4</sup> W109 p.100



# Multifunctional

MULTIFUNCTIONEEL  
MULTIFONCTIONNEL  
MULTIFUNKTIONAL  
MULTIFUNCIONAL

ORAC

**PX198 | PX198F U-STEPS**  
Duropolymer®  
200 x 8,3 x 2 cm  
Designed by Orio Tonini



**PX198 | PX198F U-STEPS** 180°  
Duropolymer®  
200 x 8,3 x 2 cm  
Designed by Orio Tonini

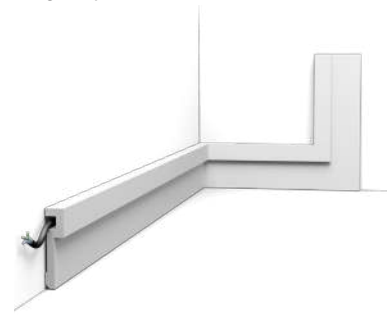

**CX190 | CX190F U-PROFILE**  
Duropolymer®  
200 x 3 x 2 cm  
Designed by Orio Tonini

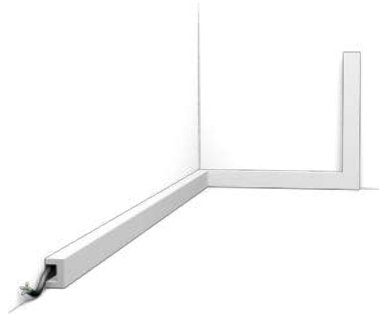

**SX159**  
Duropolymer®  
200 x 6 x 1,2 cm

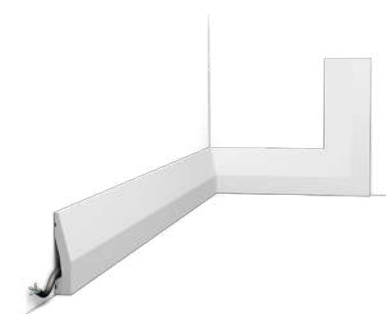

**SX194 | SX194F SQUARE**  
Duropolymer®  
200 x 2 x 1 cm

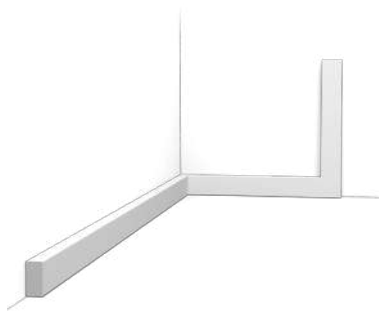

**SX162 | SX162F SQUARE**  
Duropolymer®  
200 x 4 x 1 cm

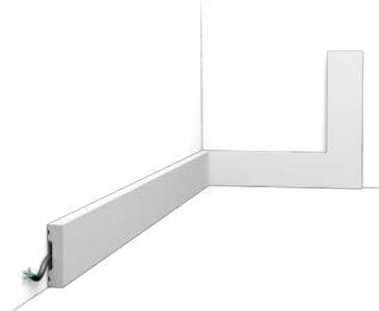

**SX157 | SX157F SQUARE**  
Duropolymer®  
200 x 6,5 x 1,3 cm

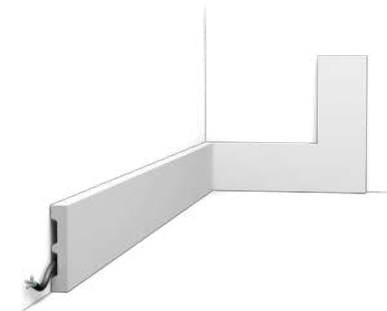

**SX163 | SX163F SQUARE**  
Duropolymer®  
200 x 10,1 x 1,3 cm

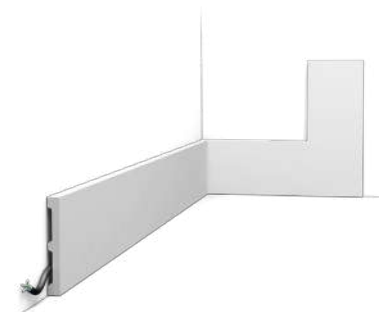
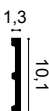

**SX168 SQUARE**  
Duropolymer®  
200 x 15 x 1,3 cm

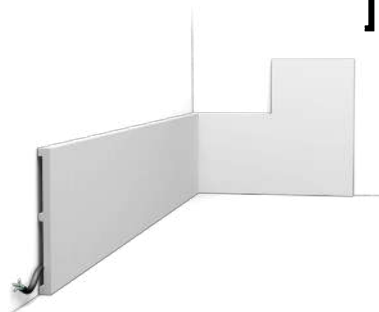

**SX207 | SX207F SQUARE**  
Duropolymer®  
200 x 25 x 1,3 cm

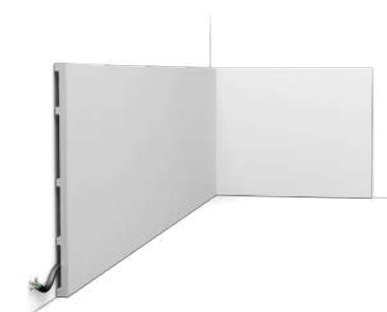

**SX187 | SX187F**  
**DX187-2600** (NEW) HIGH LINE  
 Duropolymer®  
 200 x 7,5 x 1,2 cm  
 260 x 7,5 x 1,2 cm  
 Designed by Pierre Daems



② **SX180 | SX180F**  
**DX180-2600** (NEW) HIGH LINE  
 Duropolymer®  
 200 x 12 x 1,6 cm  
 260 x 12 x 1,6 cm  
 Designed by Pierre Daems

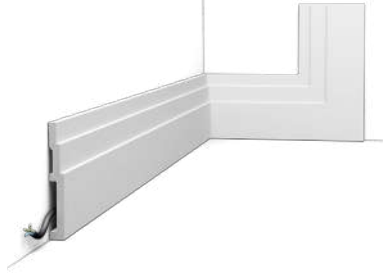

**SX181** HIGH LINE  
 Duropolymer®  
 200 x 20 x 2,2 cm  
 Designed by Pierre Daems

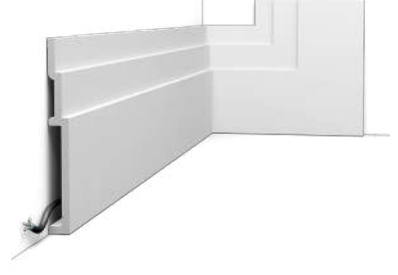
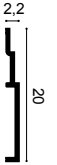

**SX182 | SX182F** CASCADE  
 Duropolymer®  
 200 x 5 x 1,3 cm



**SX183 | SX183F** CASCADE  
 Duropolymer®  
 200 x 7,5 x 1,3 cm

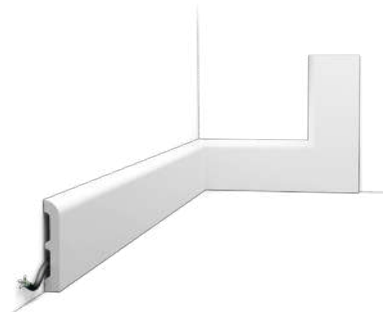

**SX184 | SX184F** CASCADE  
 Duropolymer®  
 200 x 11 x 1,3 cm

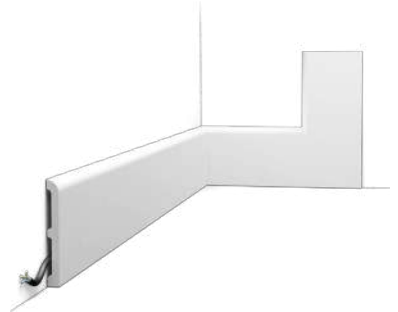
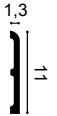

**SX212** CASCADE  
 Duropolymer®  
 200 x 17 x 1,3 cm

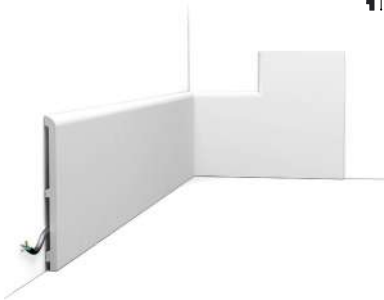

**S425 | S425F** SCALLOP (NEW)  
 Purotouch®  
 200 x 1 x 15cm  
 Designed by Roelfien Vos

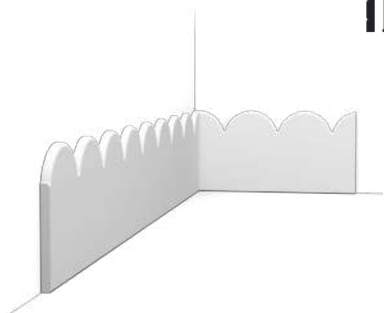

1. P7070 p.130 2. SX180



<sup>1</sup>. CX190 p.89



OVERZETPLINTEN  
SURPLINTHES  
ABDECK-SOCKELLEISTEN  
CUBRE RODAPIÉ

# Cover skirting boards

Skirting boards



## Paintable

Overschilderbaar  
Peut être peinte  
Überstreichbar  
Listo para pintar

## Water resistant

Waterbestendig  
Résistante à l'eau  
Wasserfest  
Resistente al agua

## Ideal for renovations

Ideaal voor renovatie  
Idéale pour les rénovations  
Ideal für die Renovierung  
Ideal para reformas

2. PX175 p.135 3. SX185

**SX171 | SX171-RAL9003 SQUARE**  
Duopolymer®  
200 x 10 x 2,2 cm

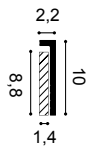

3. **SX185 CASCADE**  
Duopolymer®  
200 x 12 x 2,5 cm

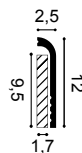

**SX186 CONTOUR**  
Duopolymer®  
200 x 13,8 x 2,2 cm

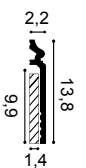

# Panel mouldings

04



WANDLIJSTEN  
CIMAISES  
WAND - UND FRIESLEISTEN  
MOLDURAS

An empty wall is like a bare base,  
in need of shape and dimension.  
Which is why we love to entertain  
ideas with these versatile accents.  
By using our panel mouldings,  
harmony comes into play, a sense  
of proportion that is balanced and  
pleasing to the eye.

**NL —**

Een lege muur is als een onbeschreven blad, klaar om vorm en dimensie te krijgen. Daarom spelen we graag met ideeën die deze veelzijdige accenten benutten. Met onze paneelprofielen brengen we harmonie aan, een gevoel van evenwicht en verhouding dat het oog streelt.

**FR —**

Un mur vide ressemble à une page blanche en attente de prendre forme. C'est pourquoi nous aimons infuser de nouvelles idées avec ces accents polyvalents. L'utilisation de nos cimaises permet de créer une harmonie, un équilibre visuellement agréable et bien proportionné.

**DE —**

Eine leere Wand gleicht einer blanken Grundlage, die Form und Dimension bedarf. Deshalb lieben wir es, Ideen mit vielseitigen Akzenten zu entwickeln. Durch die Verwendung unserer Wandleisten kommt Harmonie ins Spiel - ein Gefühl von Proportion, das ausgewogen und angenehm für das Auge ist.

**ES —**

Una pared vacía es como un lienzo en blanco: necesita forma y dimensión. Por eso nos encanta dar vida a tus ideas con estas referencias tan versátiles. Al utilizar molduras entra en juego la armonía y una sensación de proporción equilibrada y agradable a la vista.

① **P8030 | P8030F**

Purotouch®  
200 x 4,1 x 1,7 cm

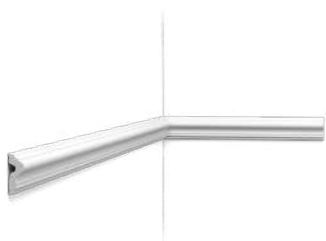

② **P8020 | P8020F**

Purotouch®  
200 x 6 x 2,6 cm



③ **P8050 | P8050F**

Purotouch®  
200 x 12 x 3 cm

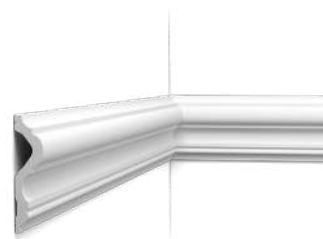

**P4020 | P4020F**

Purotouch®  
200 x 5 x 2,9 cm

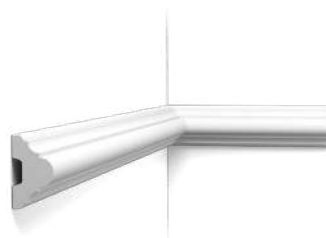

**P9040**

Purotouch®  
200 x 5 x 2,5 cm

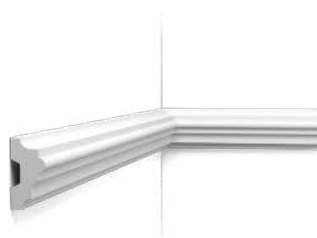

**P4025 | P4025F AUTOIRE**

Purotouch®  
200 x 8,3 x 3,4 cm  
*Designed by Orio Tonini*

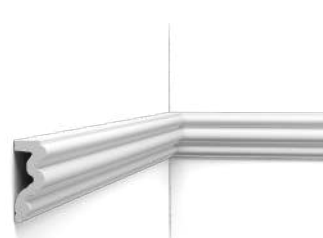
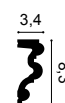

**P9010 | P9010F**

Purotouch®  
200 x 9,1 x 3 cm

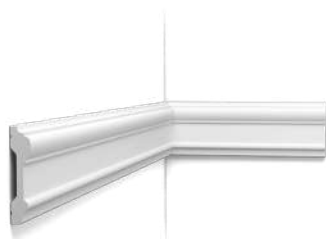
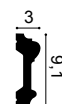

**P8040 | P8040F**

Purotouch®  
200 x 10,1 x 2,2 cm



**P9020**

Purotouch®  
200 x 9,6 x 2,1 cm



**P4000**

Purotouch®  
200 x 14,5 x 5,5 cm



**P4010**

Purotouch®  
200 x 14,5 x 5,5 cm



**P1020**  
Purotouch®  
200 x 4,9 x 2,4 cm

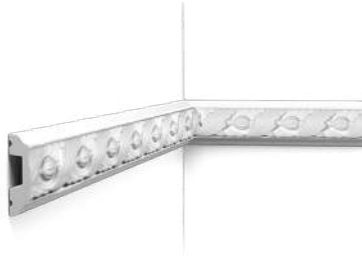

**P3020 | P3020F**  
Purotouch®  
200 x 6,1 x 3,2 cm



1. P8050 2. P8020 3. P8030



**P6020**  
Purotouch®  
200 x 6,4 x 2,8 cm

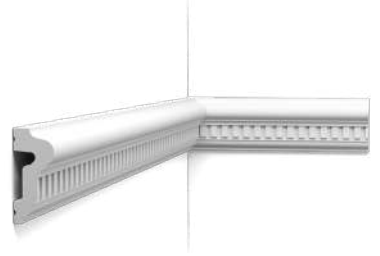

**P7030**  
Purotouch®  
200 x 8,5 x 1,7 cm

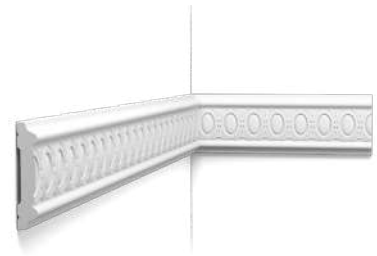

**P7020**  
Purotouch®  
200 x 11,1 x 1,9 cm

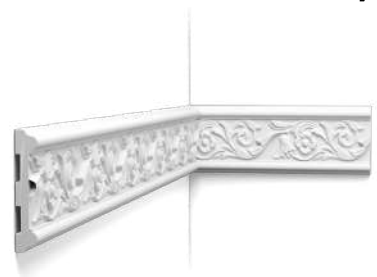

Panel mouldings

② **P9050 | P9050F**  
Purotouch®  
200 x 2,5 x 1,3 cm

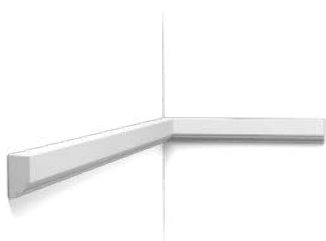

**P5021 | P5021F**  
Purotouch®  
200 x 3,1 x 0,9 cm

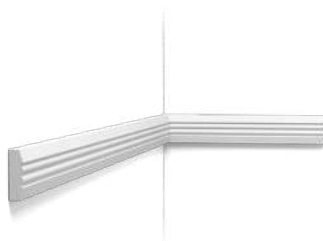

**P7070 | P7070F**  
Purotouch®  
200 x 7,4 x 2,2 cm

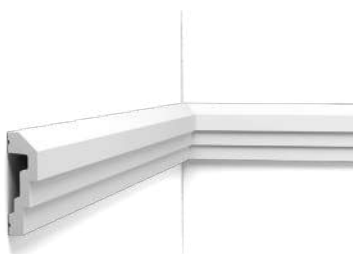

**P8060**  
Purotouch®  
200 x 5 x 3,5 cm

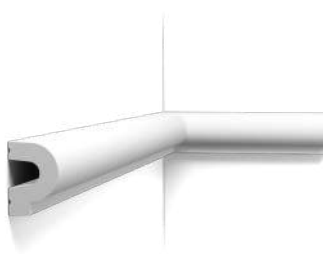

**P9900 | P9900F**  
Purotouch®  
200 x 8 x 1 cm

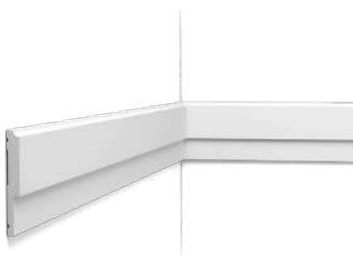

**P9901**  
Purotouch®  
200 x 7 x 1,4 cm

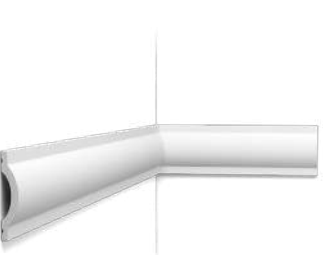

**P3070 RADIUS**  
Purotouch®  
200 x 12,5 x 3,2 cm  
*Designed by Ulf Moritz*

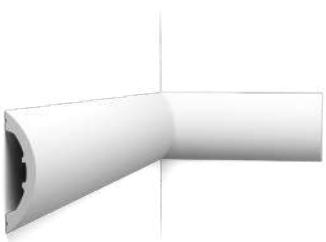
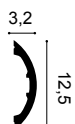

**P3071 GOLF**  
Purotouch®  
200 x 37,2 x 7,6 cm  
*Designed by Ulf Moritz*

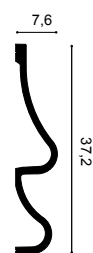



Panel mouldings

1- P9010 p.128 2- P9050 3- SX155 p.116

**P9902 | P9902F LINK** (NEW)  
 Purotouch®  
 200 x 7 x 1,5 cm  
 Designed by Roelfien Vos

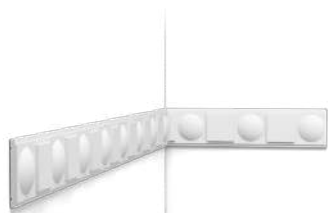

**P9903 | P9903F BOBBIN** (NEW)  
 Purotouch®  
 116,6 x 6 x 1,5 cm  
 Designed by Roelfien Vos

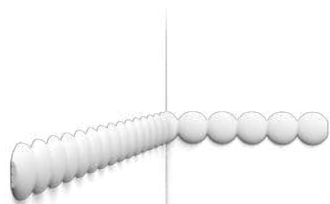

**P9904F PEARL** (NEW)  
 Purotouch®  
 200 x 2,5 x 0,9 cm  
 Designed by Roelfien Vos

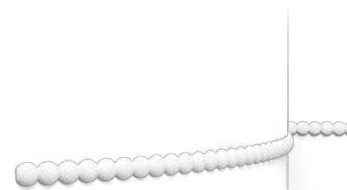

**P9905 | P9905F MEDALLION** (NEW)  
 Purotouch®  
 200 x 6 x 1,2 cm  
 Designed by Roelfien Vos

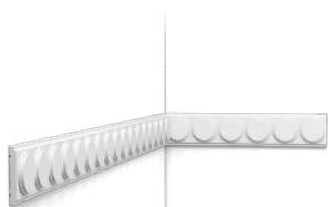

**S425 | S425F SCALLOP** (NEW)  
 Purotouch®  
 200 x 15 x 1 cm  
 Designed by Roelfien Vos

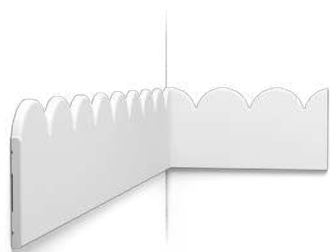



Panel mouldings

1. P9905 2. P9903 3. S425 p.123

**DX174-2600** **NEW** | **DX174F**  
 Duopolymer®  
 260 x 6 x 2,2 cm (DX174-2600)  
 200 x 6 x 2,2 cm (DX174F)

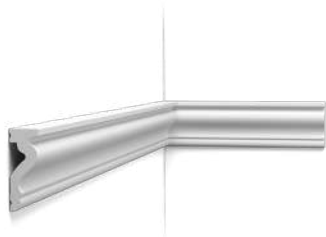

**DX170-2600** **NEW**  
 Duopolymer®  
 260 x 11,9 x 3,2 cm

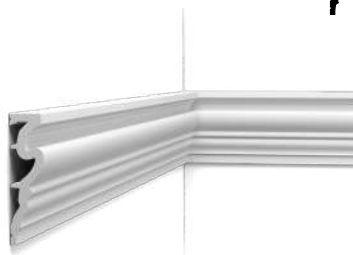

**DX119-2600** **NEW**  
 Duopolymer®  
 260 x 9,2 x 2,2 cm



<sup>1</sup>. P8020 p.128   <sup>2</sup>. P4020 p.128   <sup>3</sup>. SX206 p.117

**DX121-2600** **NEW**  
 Duopolymer®  
 260 x 9,4 x 2,3 cm

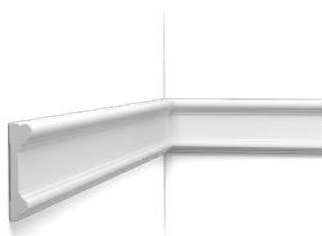
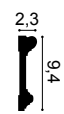

①

②

①

③

**PX103 | PX103F**  
Duopolymer®  
200 x 2,5 x 1,2 cm

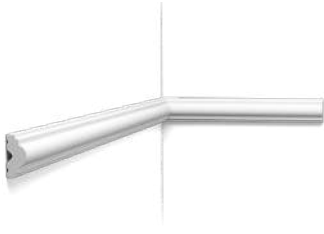

**PX120 | PX120F**  
Duopolymer®  
200 x 4 x 1,9 cm

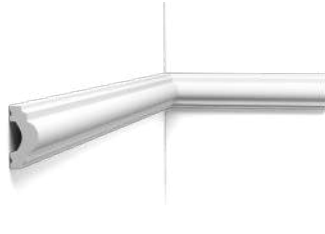

**PX201 | PX201F**  
Duopolymer®  
200 x 2,5 x 0,9 cm

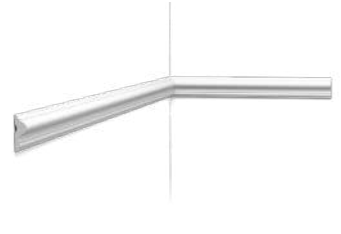

**PX175 | PX175F**  
Duopolymer®  
200 x 5 x 1,7 cm

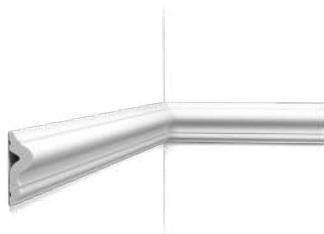

**PX202 | PX202F**  
Duopolymer®  
200 x 7,5 x 2 cm

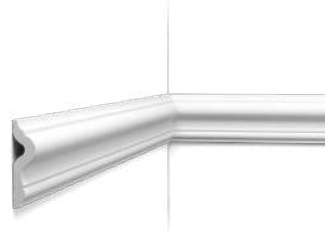

**PX116**  
Duopolymer®  
200 x 3,1 x 1 cm

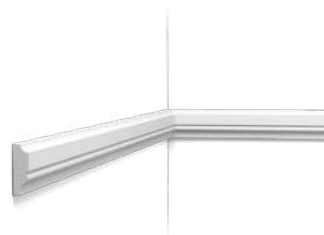

**PX117**  
Duopolymer®  
200 x 3,5 x 1,5 cm



**PX113**  
Duopolymer®  
200 x 6 x 2,7 cm

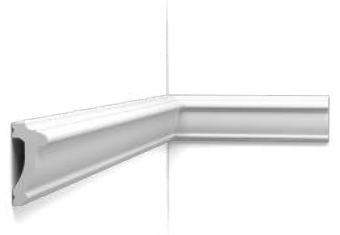

**PX144 | PX144F**  
Duopolymer®  
200 x 4,7 x 0,8 cm



**SX159**  
Duopolymer®  
200 x 6 x 1,2 cm

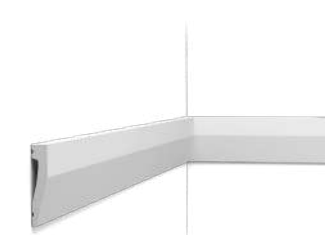



1. PX209 2. SX207

**PX169** (A)  
Duropolymer®  
200 x 5,5 x 3,4 cm

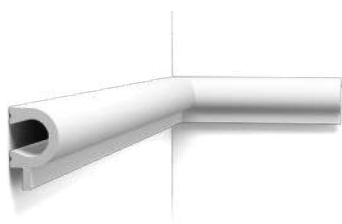

**PX147** (B)  
Duropolymer®  
200 x 16,9 x 0,9 cm

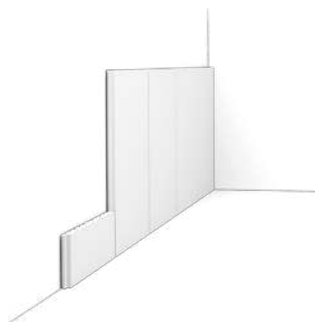
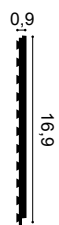

**PX169 + PX147**



**CX190 | CX190F** U-PROFILE  
Duropolymer®  
200 x 3 x 2 cm  
Designed by Orio Tonini

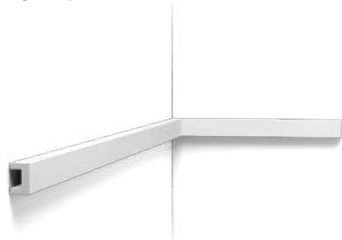

**PX198 | PX198F** U-STEPS  
Duropolymer®  
200 x 8,3 x 2 cm  
Designed by Orio Tonini

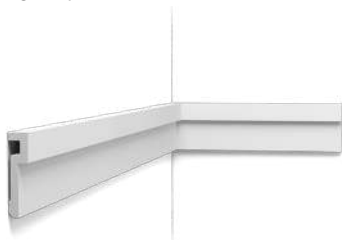

**CX197** U-STEPS  
Duropolymer®  
200 x 9,3 x 5 cm  
Designed by Orio Tonini

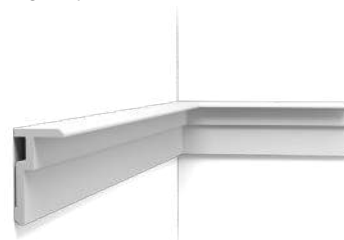
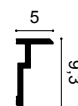

**SX194 | SX194F SQUARE**  
Duopolymer®  
200 x 2 x 1 cm

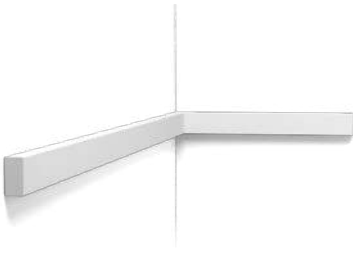

**SX162 | SX162F SQUARE**  
Duopolymer®  
200 x 4 x 1 cm

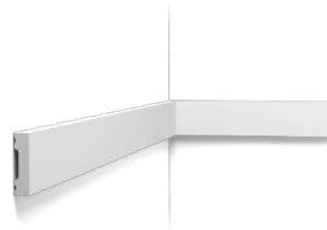

**SX157 | SX157F SQUARE**  
Duopolymer®  
200 x 6,5 x 1,3 cm

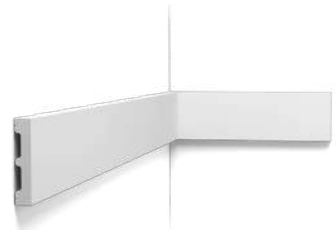

**SX163 | SX163F SQUARE**  
Duopolymer®  
200 x 10,1 x 1,3 cm

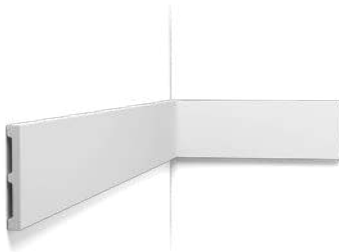
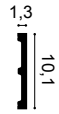

**SX168 SQUARE**  
Duopolymer®  
200 x 15 x 1,3 cm

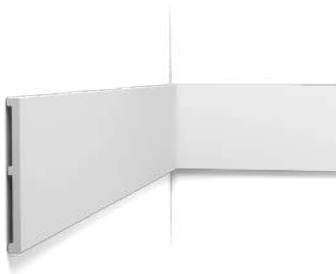
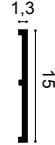

② **SX207 | SX207F SQUARE**  
Duopolymer®  
200 x 25 x 1,3 cm

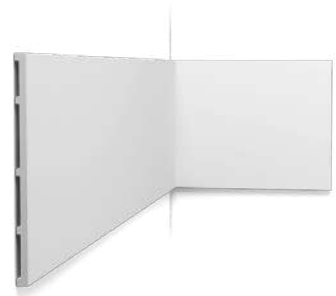
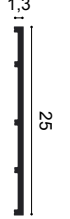

**SX182 | SX182F CASCADE**  
Duopolymer®  
200 x 5 x 1,3 cm

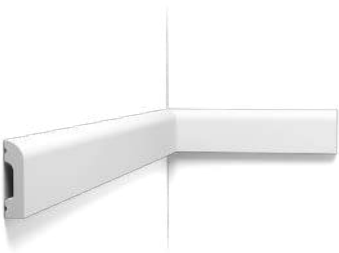

**SX183 | SX183F CASCADE**  
Duopolymer®  
200 x 7,5 x 1,3 cm

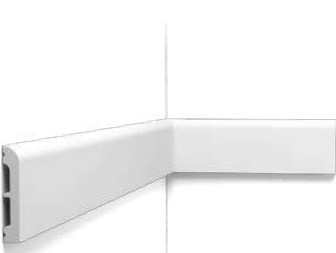

**SX184 | SX184F CASCADE**  
Duopolymer®  
200 x 11 x 1,3 cm

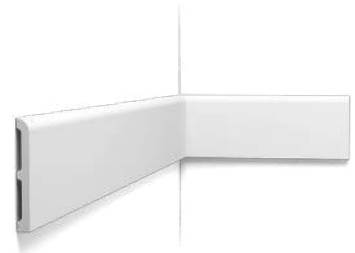
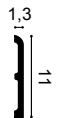

**SX212 CASCADE**  
Duopolymer®  
200 x 17 x 1,3 cm

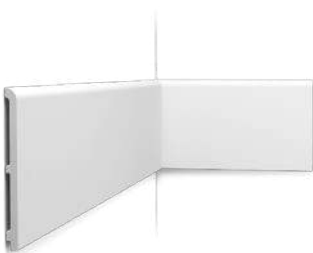

① **PX209 | PX209F RIBBON**  
Duopolymer®  
200 x 1 x 1,8 cm  
*Designed by Orio Tonini*

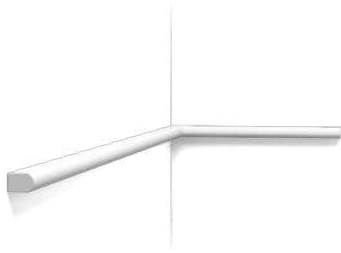

**CX134**  
Duopolymer®  
200 x 3 x 3 cm

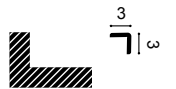

1. P3020 p.129 2. P3020A 3. P8050 p.128



**P101A + P1020**  
Purotouch®  
24,5 x 24,5 x 2,4 cm

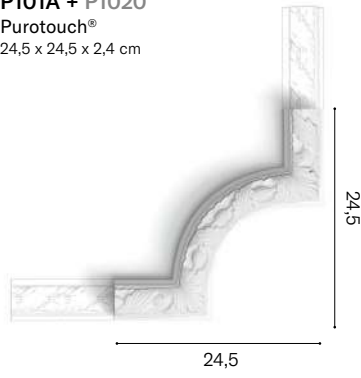

**P801C + P8020**  
Purotouch®  
19,8 x 11 x 2,6 cm



**P4020A + P4020**  
Purotouch®  
16,4 x 9,1 x 2,9 cm

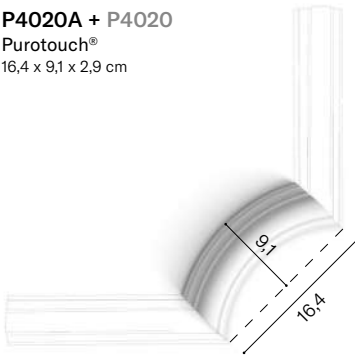

**P3020A + P3020**  
Purotouch®  
42,5 x 42,5 x 4 cm

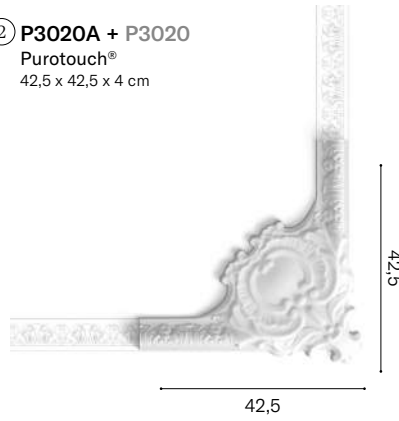

**P20 + P101A**  
Duropolymer®  
Ø 6,1 - 0,8 cm

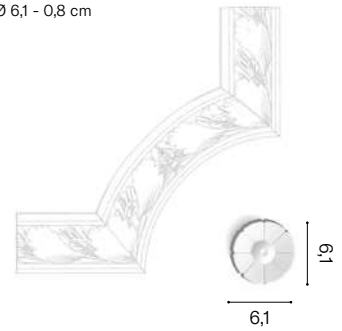

**PX103A + PX103**  
Duropolymer®  
19 x 6,8 x 1,5 cm

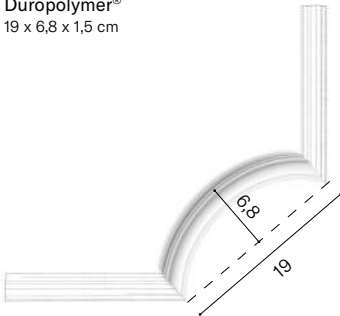

**P8030D + P8030**  
Duropolymer®  
13,2 x 13,2 x 1,7 cm

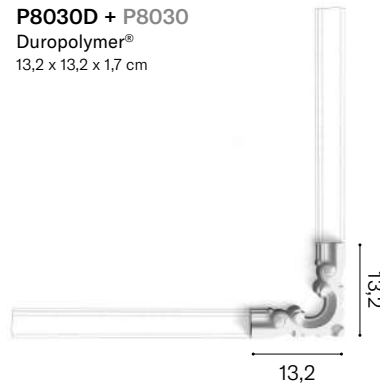

**PX120A + PX120**  
Duropolymer®  
20 x 8,8 x 2 cm

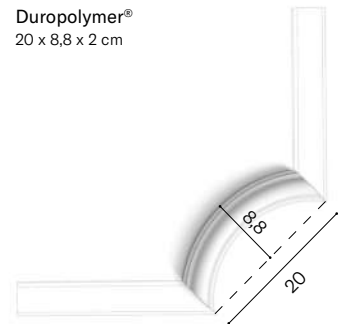

**P8030C + P8030**  
Duropolymer®  
19 x 8,6 x 1,7 cm

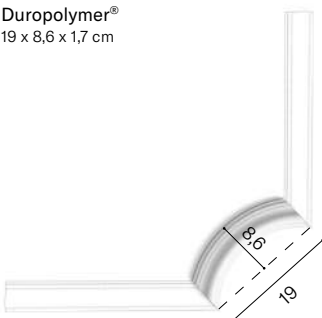

*the perfect finish*



PG.162-165

# Indirect lighting

05

INDIRECTE VERLICHTING  
ÉCLAIRAGE INDIRECT  
INDIREKTE BELEUCHTUNG  
ILUMINACIÓN INDIRECTA

Our indirect lighting solutions are the unseen maestros of ambiance. They are as versatile as they are subtle, designed to enhance every line and curve. So, we encourage you to integrate them as you see fit, for you to create an atmosphere that complements the time of day and the essence of the moment.

**NL —**  
Onze indirecte verlichting zijn de onzichtbare dirigenten van sfeer. Ze zijn net zo veelzijdig als subtiel, ontworpen om elke lijn en ronding tot hun recht te laten komen. Creëer een omgeving die het moment van de dag en het 'nu' van het moment versterkt.

**FR —**  
Nos solutions d'éclairage indirect sont les maîtres invisibles de l'ambiance. Aussi polyvalentes que subtiles, elles sont conçues pour mettre en valeur chaque ligne et chaque courbe. Nous vous encourageons donc à les intégrer comme bon vous semble, afin de créer une atmosphère qui s'accorde avec l'heure de la journée et l'essence du moment.

**DE —**  
Unsere indirekten Beleuchtungslösungen sind die unsichtbaren Meister des Ambientes. Sie sind ebenso vielseitig wie subtil und betonen jede Linie und jede Kurve. Wir möchten Sie daher ermutigen, sie nach Ihrem Geschmack zu integrieren, um eine Atmosphäre zu schaffen, die der Essenz des Augenblicks gerecht wird.

**ES —**  
Nuestras soluciones de iluminación indirecta son los artifices ocultos del ambiente. Son tan versátiles como sutiles, diseñados para realzar cada línea y curva. Por ello, animamos a integrarlos para crear una atmósfera que armonice con el momento del día y capture la esencia de cada instante.

② **C323**  
Purotouch®  
200 x 5,5 x 4,2 cm

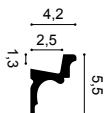

**C328** NEW  
Purotouch®  
200 x 9 x 6,8 cm

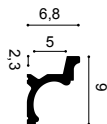

**C324** AUTOIRE  
Purotouch®  
200 x 8,3 x 3,4 cm  
*Designed by Orio Torini*

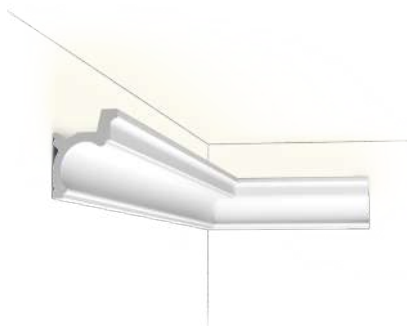

1. W212 p.100 2. C323 3. W109 p.100 4. PX209 p.137 5. SX118 p.115



**C357 STRAIGHT**

Purotouch®  
200 x 7,1 x 11 cm

Designed by Jacques Vergracht

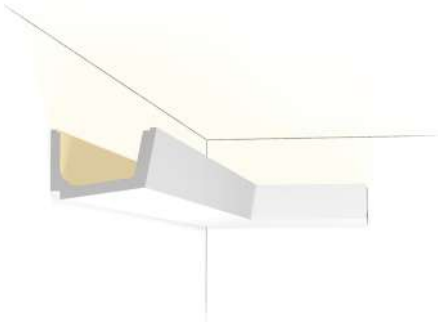
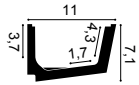

**C352 FLAT**

Purotouch®  
200 x 7,6 x 17,1 cm

Designed by Jacques Vergracht

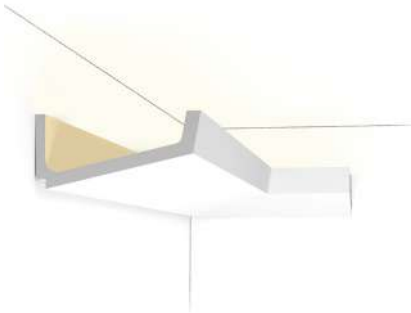

6 C902

Indirect lighting

6 **C902 | C902F**

Purotouch®  
200 x 10,3 x 10,3 cm

Designed by Jacques Vergracht

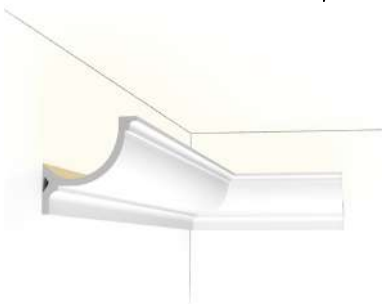
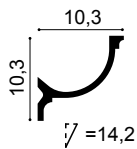

**C901 | C901F**

Purotouch®  
200 x 14,8 x 12,4 cm

Designed by Jacques Vergracht

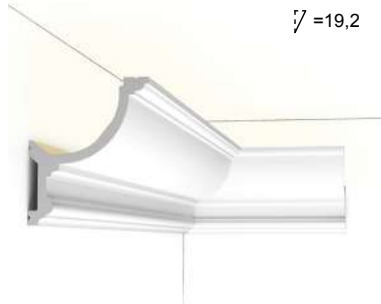
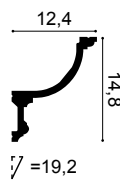

**C900**

Purotouch®  
200 x 17,1 x 14,6 cm

Designed by Jacques Vergracht

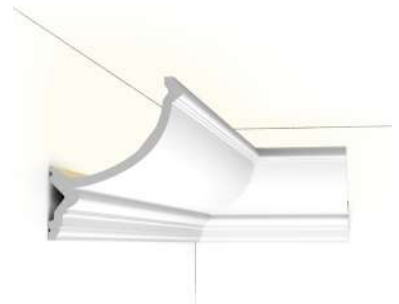

# L3 lighting combinations

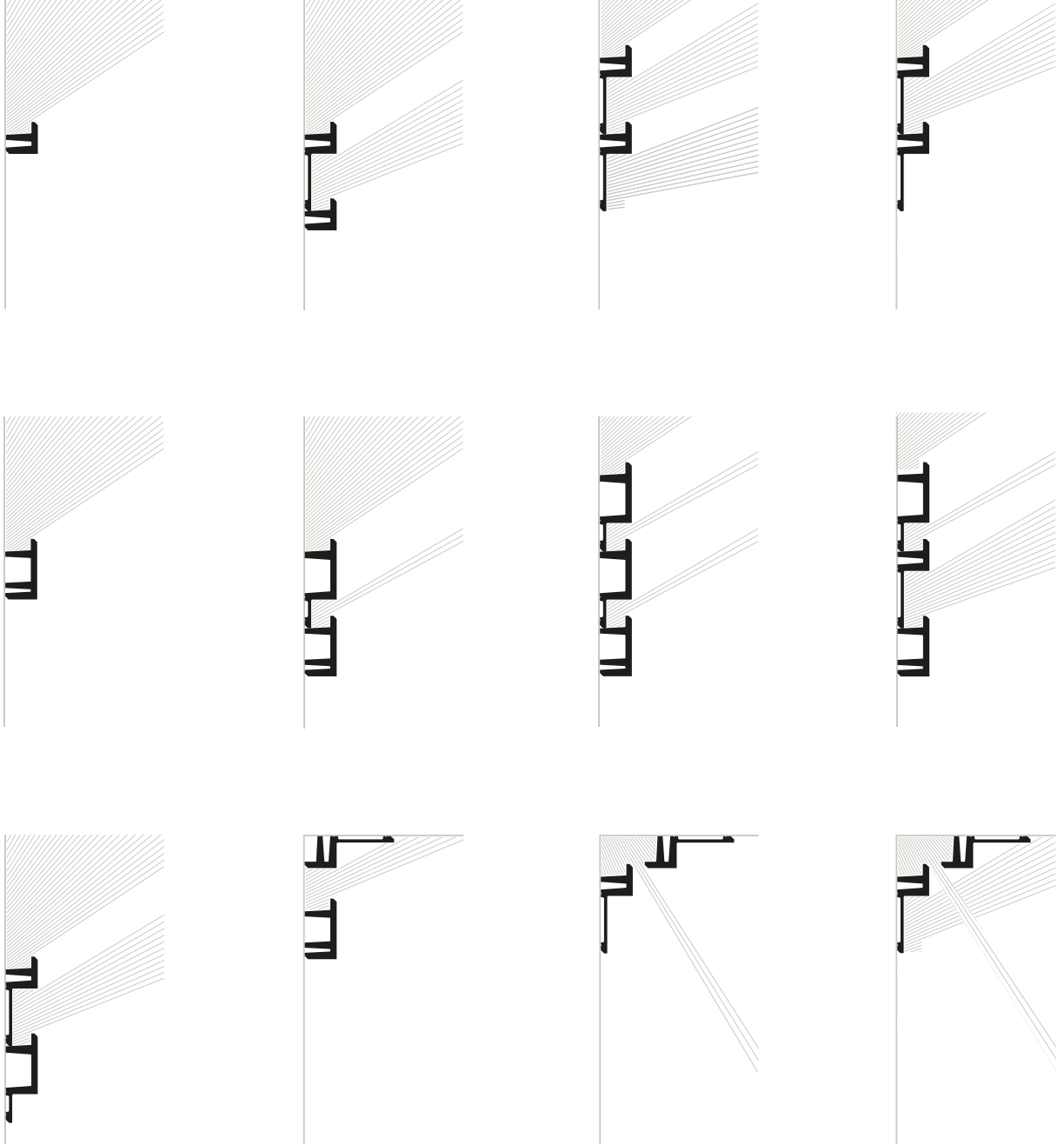



① **C380** L3 LINEAR LED LIGHTING  
 Purotouch®  
 200 x 5 x 5 cm  
 Designed by Orio Tonini

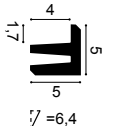

**C381** L3 LINEAR LED LIGHTING  
 Purotouch®  
 200 x 9,5 x 5 cm  
 Designed by Orio Tonini

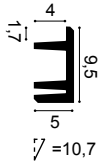

**C382** L3 LINEAR LED LIGHTING  
 Purotouch®  
 200 x 14 x 5 cm  
 Designed by Orio Tonini

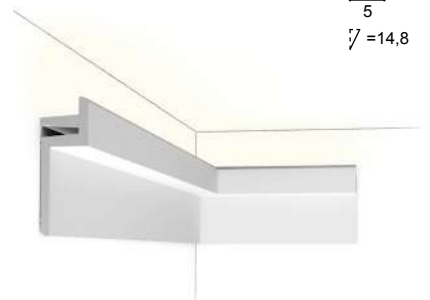
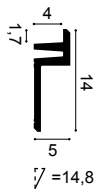

**C383** L3 LINEAR LED LIGHTING  
 Purotouch®  
 200 x 14 x 5 cm  
 Designed by Orio Tonini

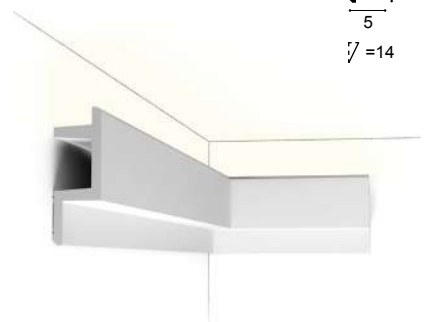
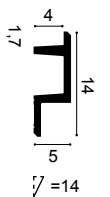

Indirect lighting

1. C380 2. SX180 p.128

1. C394 2. C393 p.79 3. SX180 p.128



C394

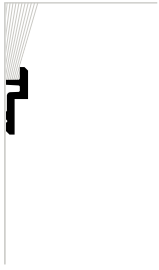

C395

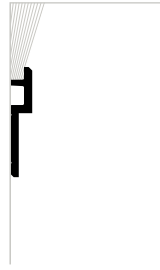

C396

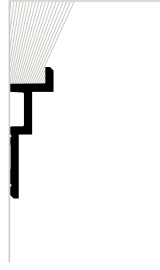

Uplighter

C390

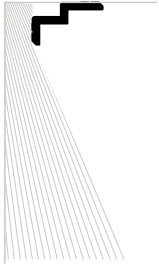

C391

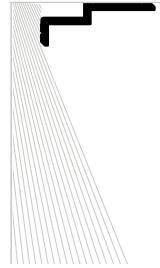

C394

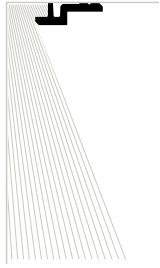

C395

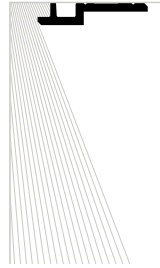

Downlighter

**C390 STEPS**  
Purotouch®  
200 x 6 x 10 cm  
Designed by Orio Tonini

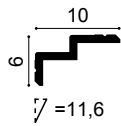

**C391 STEPS**  
Purotouch®  
200 x 6 x 16 cm  
Designed by Orio Tonini

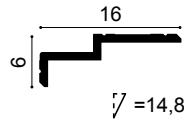

① **C394 STEPS**  
Purotouch®  
200 x 9,5 x 3,1 cm  
Designed by Orio Tonini

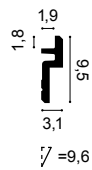

**C395 STEPS**  
Purotouch®  
200 x 15,5 x 3,1 cm  
Designed by Orio Tonini

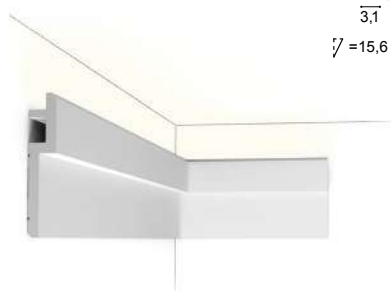

**C396 STEPS**  
Purotouch®  
200 x 18,5 x 6,1 cm  
Designed by Orio Tonini

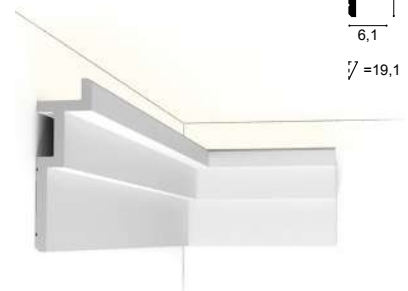
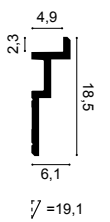

① **CX215-2600** LEDGE (NEW)  
 Duopolymer®  
 260 x 9,5 x 4,5 cm



**CX216-2600** LEDGE (NEW)  
 Duopolymer®  
 260 x 12,5 x 4,5 cm



**CX217-2600** LEDGE (NEW)  
 Duopolymer®  
 260 x 15,5 x 5 cm



**CX215-2600** LEDGE (NEW)  
**CURTAIN PROFILE**  
 Duopolymer®  
 260 x 9,5 x 4,5 cm



**CX216-2600** LEDGE (NEW)  
**CURTAIN PROFILE**  
 Duopolymer®  
 260 x 12,5 x 4,5 cm



**CX217-2600** LEDGE (NEW)  
**CURTAIN PROFILE**  
 Duopolymer®  
 260 x 15,5 x 5 cm



1. C215 2. SX157 p.115



Indirect lighting

**SX179 DIAGONAL**  
 Duropolymer®  
 200 x 9,7 x 2,9 cm  
 Designed by Orio Tonini

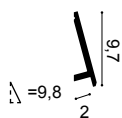

**SX179 DIAGONAL**  
 Duropolymer®  
 200 x 9,7 x 2,9 cm  
 Designed by Orio Tonini



Use aluminium  
 tape or bar for  
 LED lighting

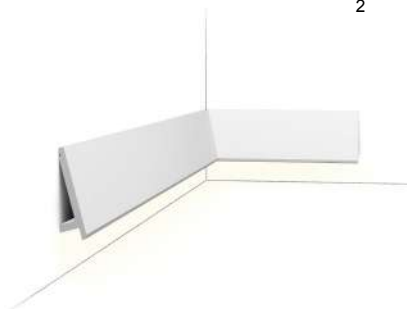
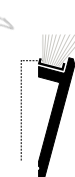

**CX197 U-STEPS**  
 Duropolymer®  
 200 x 5 x 9,3 cm  
 Designed by Orio Tonini

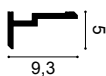

**CX196 U-STEPS**  
 Duropolymer®  
 200 x 11,3 x 4 cm  
 Designed by Orio Tonini

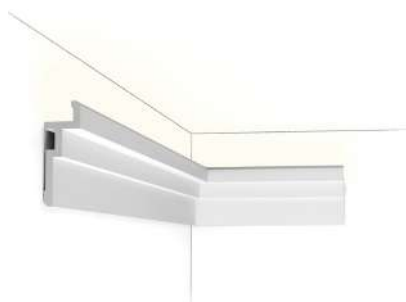

**CX188 | CX188F**  
 Duropolymer®  
 200 x 3,4 x 3 cm  
 Designed by Orio Tonini



**CX189 | CX189F**  
 Duropolymer®  
 200 x 2,7 x 2,7 cm  
 Designed by Orio Tonini



**CX190 | CX190F U-PROFILE**  
 Duropolymer®  
 200 x 2 x 3 cm  
 Designed by Orio Tonini



**CX190 | CX190F U-PROFILE**  
 Duropolymer®  
 200 x 2 x 3 cm  
 Designed by Orio Tonini



**CX190 | CX190F U-PROFILE**  
 Duropolymer®  
 200 x 2 x 3 cm  
 Designed by Orio Tonini

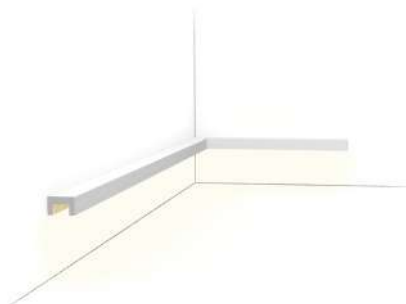



Indirect lighting

1. CX196 2. W115 p.104 3. CX190 p.89

**C373 | C373F ANTONIO**  
 Purotouch®  
 200 x 8 x 5 cm  
 Designed by Ulf Moritz



**C374 ANTONIO**  
 Purotouch®  
 200 x 18 x 5 cm  
 Designed by Ulf Moritz

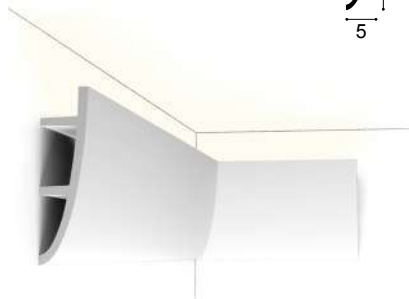
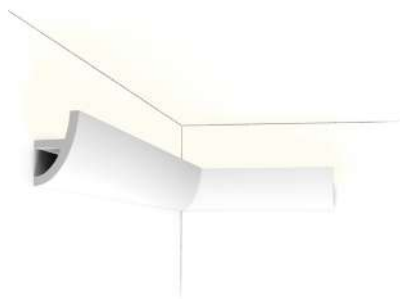
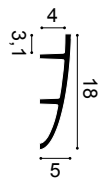

# Antonio

C373 + C374

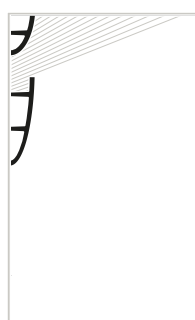

C373 + C373

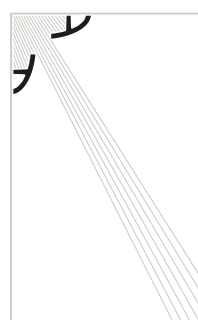

C374 + C991

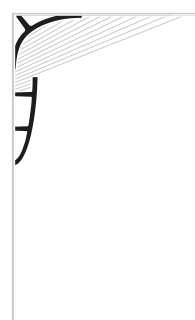

C373 + C373

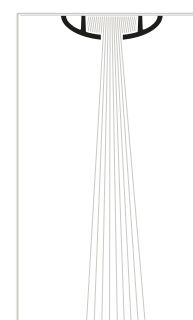

C374 + C374

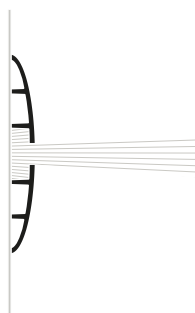

C373 + C374

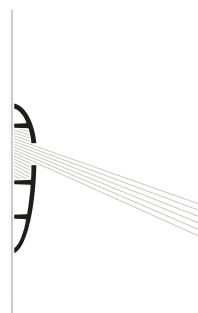

C373 + C373

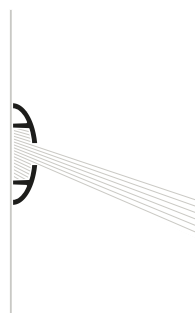

C374 + C373

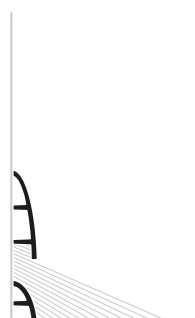

C373 + C374

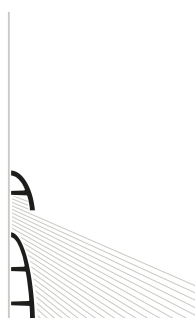

C374 + C374

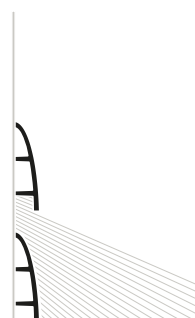

1. PX120 p.135 2. C394 p.79 3. C991 p.77 4. C361 p.154



**C361 STRIPE**  
 Purotouch®  
 200 x 5 x 5 cm  
 Designed by Pierre Daems



**C362 CURVE**  
 Purotouch®  
 200 x 5 x 5 cm  
 Designed by Pierre Daems

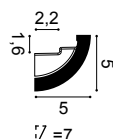

① **C991**  
 Purotouch®  
 200 x 11 x 14 cm  
 Designed by Ulf Moritz

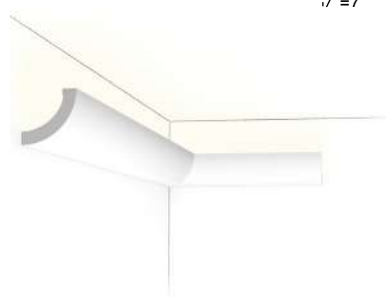
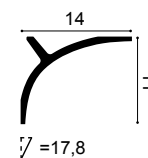

**C371 SHADE**  
 Purotouch®  
 200 x 18,5 x 5,8 cm  
 Designed by Ulf Moritz

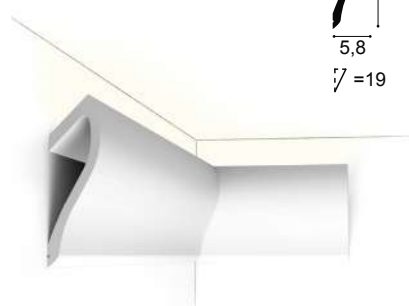
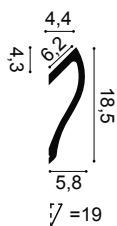

*the perfect finish*



1. C991



# Deco elements

06



DECORATIEVE ELEMENTEN  
ÉLÉMENTS DÉCORATIFS  
ZIERELEMENTE  
ELEMENTOS DE DECORACIÓN

Deco elements are the subtle whispers of personality that breathe life into a space. From grandiose flourishes to understated accents, we propose options to punctuate your interior design narrative with finesse, for you to find what feels right.

**NL —**  
Decoratieve elementen zijn zachte echos van persoonlijkheden die een ruimte nieuw leven in blazen. Van imposante uitspattingen tot ingetogen accenten, wij bieden opties om jouw interieurverhaal met verfijning te accentueren, zodat je vindt wat echt bij je past.

**FR —**  
Les éléments déco sont de subtils murmures de personnalité qui insufflent de la vie à un espace. Qu'il s'agisse d'ornements grandioses ou d'accents discrets, nous vous proposons des options pour ponctuer avec finesse votre récit de décoration intérieure, afin que vous trouviez ce qui vous convient.

**DE —**  
Dekorative Elemente sind die subtilen Ausdrücke der Persönlichkeit, die einem Raum Leben einhauchen. Wir bieten Ihnen, von prunkvollen Verzierungen bis hin zu dezenten Akzenten, Optionen, um Ihre Inneneinrichtung mit Finesse zu unterstreichen und genau das zu finden, was sich für Sie richtig anfühlt.

**ES —**  
Los elementos decorativos son matices delicados que dan vida y personalidad a un espacio. Desde los elementos más llamativos hasta matices los más discretos. Proponemos opciones para desarrollar la narrativa de tu diseño de interiores y poder encontrar lo que realmente conecta contigo.

# Ceiling roses

ROZETTEN  
ROSACES  
ROSETTEN  
ROSETONES

ORAC



1. R64

R10   
Purotouch®

ø 15 x 4,2 - ø 2 cm



R11  
Purotouch®  
ø 19 x 3,6 - ø 3 cm



R12  
Purotouch®  
ø 19,5 x 1,8 - ø 1 cm



**R13**   
Purotouch®  
ø 28 x 3,1 - ø 2,5 cm



**R14**   
Purotouch®  
ø 33 x 3 - ø 2,5 cm



**R31**   
Purotouch®  
ø 38,5 x 2,7 - ø 3,5 cm



**R17**   
Purotouch®  
ø 47 x 3,5 - ø 6,5 cm



**R18**  
Purotouch®  
ø 49 x 4,7 - ø 7 cm



**R52**   
Purotouch®  
ø 69,5 x 4,8 - ø 12,5 cm



**R73**   
Purotouch®  
ø 70 x 5,9 - ø 8 cm



**R23**  
Purotouch®  
ø 71 x 4,4 - ø 6 cm



**R27**  
Purotouch®  
ø 75 x 4,5 - ø 9 cm



**R22**  
Purotouch®  
77,5 x 53 x 3,6 cm



**R24**  
Purotouch®  
ø 79 x 6 - ø 8 cm



**R64**   
Purotouch®  
ø 95,2 x 4,8 - ø 7 cm



**R07**  
Purotouch®  
ø 26 x 3 - ø 5 cm



**R08**  
Purotouch®  
ø 38 x 4,2 - ø 5 cm



**R09** ⊕  
Purotouch®  
ø 48,5 x 3,7 - ø 6 cm



**R76**  
Purotouch®  
ø 62 x 4,1 - ø 10,5 cm



① **R77**  
Purotouch®  
ø 62 x 4,2 - ø 10,5 cm



**R40** ⊕  
Purotouch®  
ø 74,5 x 3,1 - ø 10 cm

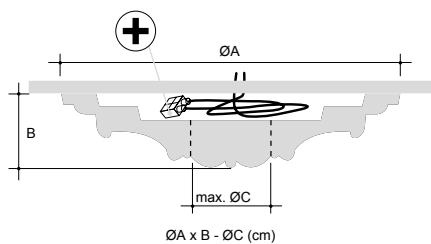

⊕ Room for cables

HOLTE VOOR KABELS  
PLACE POUR LES CÂBLES  
HOHLRAUM FÜR KABEL  
ESPACIO PARA CABLES



Deco elements

1. R77

# Door frames

DEUROMLIJSTINGEN  
ENCADREMENTS DE PORTES  
TÜRUMRÄNDUNGEN  
MARCOS PARA PUERTAS

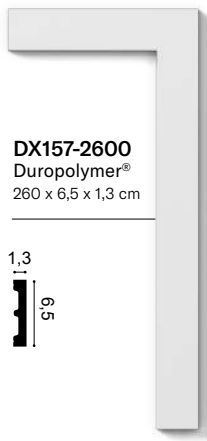

**DX157-2600**  
Duropolymer®  
260 x 6,5 x 1,3 cm

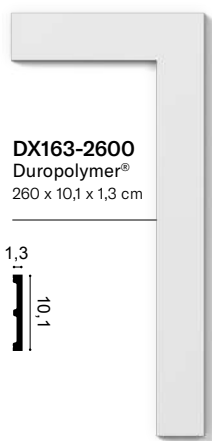

**DX163-2600**  
Duropolymer®  
260 x 10,1 x 1,3 cm



**DX187-2600** (NEW)  
HIGH LINE  
Duropolymer®  
260 x 7,5 x 1,2 cm



**DX180-2600** (NEW)  
HIGH LINE  
Duropolymer®  
260 x 12 x 1,6 cm



**D210**  
Duropolymer®  
9,6 x 9,6 x 3,5 cm

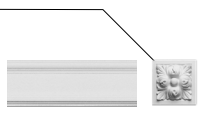

**D200**  
Duropolymer®  
9,6 x 9,6 x 3 cm

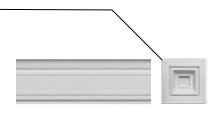

**DX121-2600**  
Duropolymer®  
260 x 9,4 x 2,3 cm



**DX119-2600**  
Duropolymer®  
260 x 9,2 x 2,2 cm



**D310**  
Duropolymer®  
9,5 x 24,9 x 3,1 cm



**D310**  
Duropolymer®  
9,5 x 24,9 x 3,1 cm

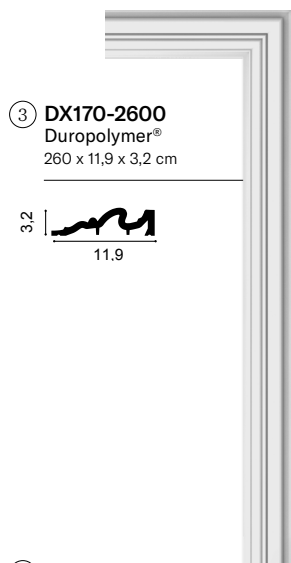

**DX170-2600**  
Duropolymer®  
260 x 11,9 x 3,2 cm

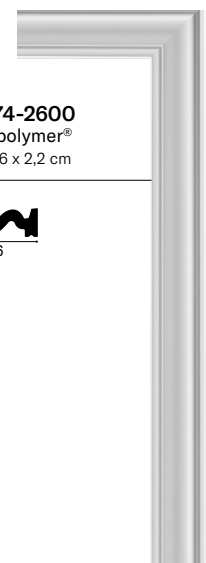
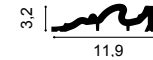

**DX174-2600**  
Duropolymer®  
260 x 6 x 2,2 cm

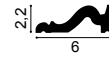

**D330LR** (2pc)  
Duropolymer®  
12,6 x 16 x 4,1 cm



**D340**  
Duropolymer®  
7 x 11 x 2,5 cm

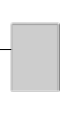

ORAC

1. D170 2. D401 3. DX170-2600 4. D330LR

Products

**D402**  
Purotouch®  
only for D400 and D401  
14,5 x 12 x 5,5 cm



① **D170**  
Purotouch®  
105 x 24,5 x 3,2 cm



**D400**  
Purotouch®  
127,5 x 14,5 x 5,5 cm  
Also available in 2m version, see **P4000** p.130

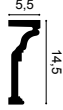

② **D401**  
Purotouch®  
127,5 x 14,5 x 5,5 cm  
Also available in 2m version, see **P4010** p.130



**D507**  
Duropolymer®  
55 x 90,5 x 1,7 cm



**D503**  
Duropolymer®  
55 x 55 x 1,7 cm

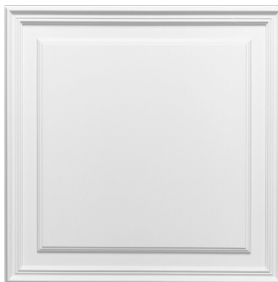

**D504**  
Duropolymer®  
55 x 22 x 1,7 cm

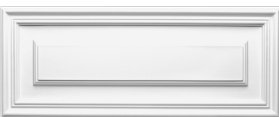

# Full columns

VOLLE ZUILEN  
COLONNES ENTIÈRES  
VOLLSÄULEN  
COLUMNAS COMPLETAS



**K1112**  
Duropolymer®  
H 30cm



**K1122**  
Duropolymer®  
H 30cm

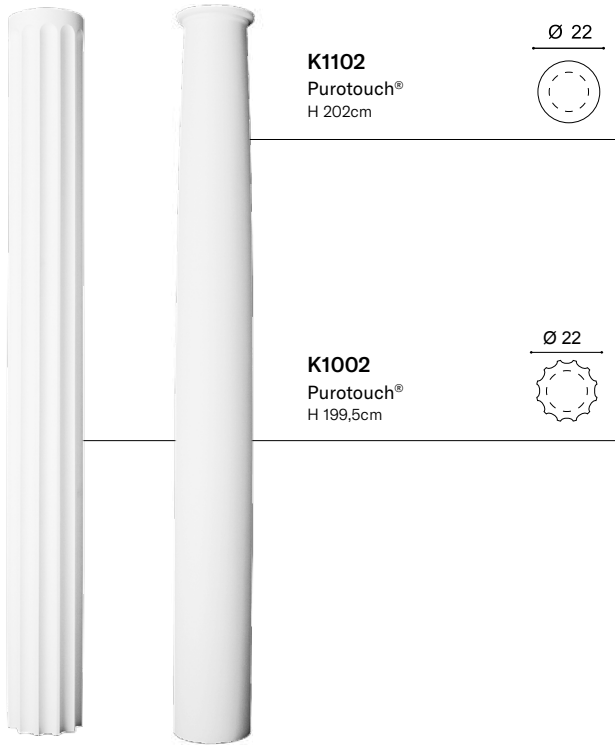

**K1102**  
Purotouch®  
H 202cm

**K1002**  
Purotouch®  
H 199,5cm



**K1152**  
Duropolymer®  
H 12,5 cm

**K1132**  
Purotouch®  
H 57,5 cm

K1112 + K1002 + K1152 = 242 cm H  
K1112 + K1002 + K1132 = 287 cm H max  
K1122 + K1102 + K1152 = 242 cm H  
K1122 + K1102 + K1132 = 287 cm H max

ORAC

# Half columns

HALVE ZUILEN  
DEMI-COLONNES  
HALBSÄULEN  
MEDIAS COLUMNAS



**K1111**  
Duropolymer®  
H 30cm



**K1121**  
Duropolymer®  
H 30cm

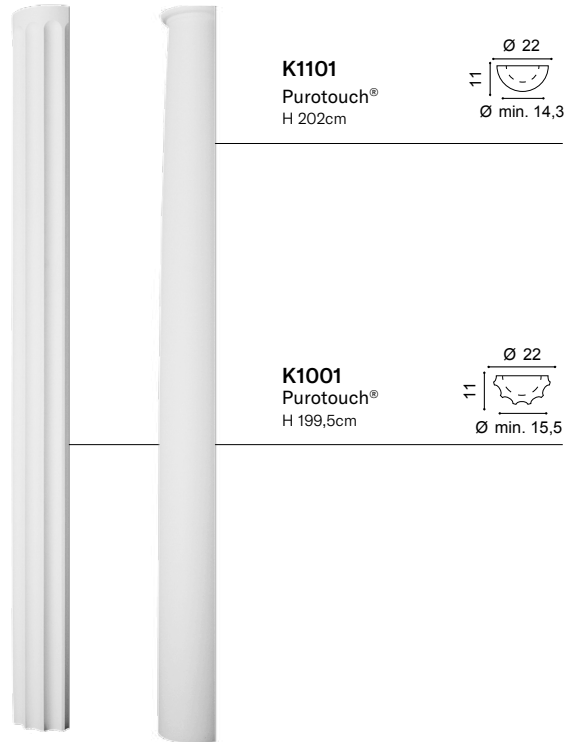

**K1101**  
Purotouch®  
H 202cm

**K1001**  
Purotouch®  
H 199,5cm



**K1151**  
Duropolymer®  
H 12,5 cm

**K1131**  
Purotouch®  
H 57,5 cm

K1111 + K1001 + K1151 = 242 cm H  
K1111 + K1001 + K1131 = 287 cm H max  
K1121 + K1101 + K1151 = 242 cm H  
K1121 + K1101 + K1131 = 287 cm H max

# Pilasters

1. K1122
2. K1002
3. K1152
4. K251
5. K250
6. K254

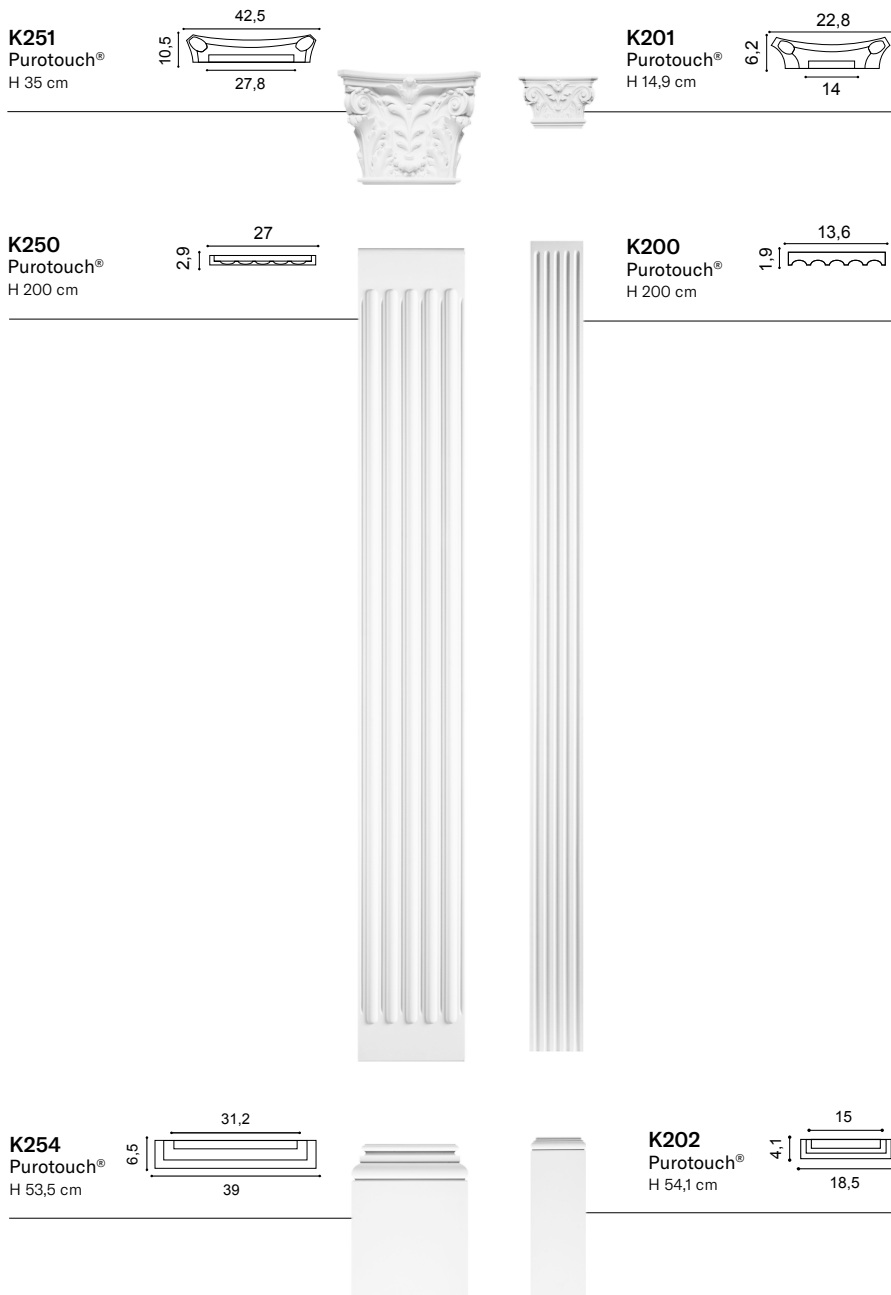

# The perfect finish

07



DE PERFECTE AFWERKING  
LA FINITION PARFAITE  
DIE PERFEKTE INSTALLATION  
EL ACABADO PERFECTO

We once vowed never to stop at what looks good. That's why our products stand the test of time, right down to the glue that holds them in place. Our installation products are the silent artisans behind the scenes, ensuring a seamless and straightforward installation of our architectural elements.

**NL —**

Onze producten zijn meer dan een lust voor het oog. Ze zijn gemaakt om de tand des tijds te doorstaan, tot aan de lijm die elk stuk op zijn plaats houdt. Onze montagematerialen zijn de onzichtbare meesterhanden die zorgen voor een vlekkeloze en eenvoudige plaatsing van onze architecturale elementen.

**FR —**

Nous nous sommes promis de ne jamais nous arrêter à ce qui est beau. C'est pourquoi nos produits résistent à l'épreuve du temps, jusqu'à la colle qui les maintient en place. Nos produits d'installation sont les artisans silencieux de l'arrière-scène, qui garantissent l'installation simple et sans faille de nos éléments architecturaux.

**DE —**

Wir haben einst geschworen, niemals bei dem Halt zu machen, was gut aussieht. Deshalb überdauern unsere Produkte, bis hin zum Klebstoff, der sie an Ort und Stelle hält, die Zeit. Unsere Installationsprodukte sind die stillen Handwerker hinter den Kulissen und sorgen für eine nahtlose und unkomplizierte Installation unserer architektonischen Elemente.

**ES —**

Un día nos comprometimos a crear belleza perdurable. Por eso nuestros productos resisten el paso del tiempo, incluso el adhesivo que los mantiene en su sitio! Nuestros productos de instalación son como artesanos silenciosos entre bastidores, que garantizan una instalación perfecta y sencilla de nuestros elementos arquitectónicos.

## Surface and atmosphere

OMGEVING & ONDERGROND  
 ENVIRONNEMENT & SURFACE  
 UMGEBUNG & UNTERGRUND  
 AMBIENTE & SUPERFICIE

Storage and installation conditions: Store profiles and adhesives at room temperature and wait 24 hours before installing.



Opslag- en plaatsingsvoorwaarden:  
 Plaats profielen en lijmen 24 uur vóór de installatie op kamertemperatuur.

Conditions d'installation et de stockage:  
 Stockez les profils et les colles à température ambiante 24 heures avant la pose.

Lager- und Installationsbedingungen:  
 Profile und Kleber 24 Stunden vor Verlegung bei Zimmertemperatur lagern.

Condiciones de almacenamiento y de instalación:  
 Colocar los productos y adhesivos a temperatura ambiente 24 horas antes de la instalación.



Dust free  
 Stofvrij  
 Sans poussière  
 Staubfrei  
 Libre de polvo



Sand and wash surface  
 Schuur en reinig de ondergrond  
 Poncez et nettoyez la surface  
 Schleifen und reinigen Sie den Untergrund  
 Superficie lisa y limpia



Flat wall & ceilings  
 Vlakke wand en plafond  
 Mur et plafond plats  
 Glatte Wand und Decke  
 Paredes y techos lisos



Dry  
 Droog  
 Sec  
 Trocken  
 Seco



No grease  
 Vetvrij  
 Sans graisse  
 Fettfrei  
 Sin grasa

## Decofix adhesives

DECOFIX LIJMEN  
 COLLES DECOFIX  
 DECOFIX KLEBER  
 DECOFIX ADHESIVOS

ONLINE GLUE CALCULATOR



Porous and dry surface  
 Poreuze en droge ondergronden  
 Surfaces poreuses, pièces non humides  
 Poröser/ saugfähiger und trockener Untergrund  
 Superficies porosas y secas



Heavy profiles  
 Zware lijsten  
 Profils lourds  
 Schwere Profile  
 Perfiles Pesados



Non-porous and humid surfaces and 3D Wall Covering  
 Niet-poreuze en vochtige ondergronden en 3D wandbekleding  
 Surfaces non poreuses, environnement humide et revêtements muraux 3D  
 Nicht-poröser/saugfähiger Untergrund und Feuchträume  
 Superficies no porosas, ambientes húmedos y paneles 3D



Seal wall/ceiling  
 Verbinding muur/plafond  
 Collage mur/plafond  
 Verbindung Wand/Decke  
 Adherencia techos/paredes



### DecoFix Pro

Strong, water-based acrylic installation adhesive

FDP500 310ml | 7 > 8m



### DecoFix Power

Very strong MS-Polymer-based installation adhesive

FDP700 290ml | 7 > 8m



Joints between mouldings\*  
 Verbinding tussen profielen  
 Joints entre les profils  
 Nahtverbindungen zwischen Profilen  
 Uniones entre los perfiles



### DecoFix Ultra

Polymer-based adhesive

FX400 270ml | min. 80m

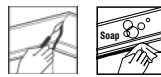

### DecoFix Ultra

Polymer-based adhesive

FX400 270ml | min. 80m



Filler & finishing  
 Vullen en afwerking  
 Enduit et finition  
 Verfugen und Endbearbeitung  
 Relleno y acabado



### DecoFiller

Acrylic filler

FL300 310ml | > 30m



### DecoFiller

Acrylic filler

FL300 310ml | > 30m



## Installation videos & manuals

VISIT [WWW.ORACDECOR.COM/INSTALLATION](http://WWW.ORACDECOR.COM/INSTALLATION) OR SCAN THE QR CODE



## DecoFix Pro



FDP500 310ml  
> 7 – 8m

Extra strong installation adhesive for porous surfaces and interior applications

- Strong, water-based acrylic glue
- Long-lasting seal between mouldings and the wall and/or ceiling
- Remove with humid sponge or cloth
- Should be kept frost free
- Paintable after hardening (min. 24 hours)

## DecoFix Power



FDP700 290ml  
> 7 - 8m

Extra strong MS polymer glue for new build, non-porous (tiles, glass, ...) surfaces, damp environments and 3D wall covering

- Remove with soap solution
- Paintable after hardening (min. 24 hours)
- Also compatible with our outdoor Xterio collection, which is exclusively available in the UK.

## DecoFix Ultra



FX400 270ml  
> 80m

White, polymer-based adhesive for joints between mouldings

- Apply sufficient DecoFix Ultra in every joint.
- Firmly press the profiles together until adhesive comes out slightly. Be careful not to push all glue out of the joint.
- Maintain a small gap (between 0 to 0.2 mm).
- Use a painter's knife to remove excess adhesive.
- Use FL300 DecoFiller if needed and finish with sandpaper.
- Can be painted after 24 hrs.

## DecoFiller



FL300 310ml  
> 30m

Ready to use lightweight acrylic filler

- For shrink-proof finishing of gaps (between decorative profiles after adhesion, between wall and profiles, between walls and between wall and ceiling), cracks and irregularities in profiles or on walls
- Rapidly repairable (after 15 min.)
- Does not crack

Extra sterke installatielijm voor poreuze ondergrond en binnentoepassingen

- Sterke acrylijm op waterbasis
- Langdurende verbinding tussen profielen en muur en/of plafond
- Verwijder met een vochtige spons of doek
- Vorstvrij bewaren
- Overschilderbaar na uitharding (min. 24u)

Extra sterke MS-polymeerlijm voor nieuwbouw, op niet-poreuze (tegels, glas,...) ondergrond, in vochtige ruimtes en voor 3D wandbekleding

- Verwijder met een zeepoplossing
- Overschilderbaar na uitharding (min. 24u)

Witte lijm op polymeerbasis voor verbindingen tussen profielen

- Gebruik voldoende DecoFix Ultra in elke naadverbinding op 1 zijde van het reeds geplaatste profiel.
- Druk de profielen stevig op elkaar tot de lijm iets naar buiten komt.
- Wees voorzichtig dat niet alle lijm uit de voeg wordt gedrukt.
- Hou een kleine opening over (tussen 0 en 0,2 mm).
- Gebruik een schildersmes om overtollige lijm te verwijderen.
- Gebruik FL300 DecoFiller indien nodig en werk af met schuurpapier.
- Overschilderbaar na 24 uur.

Kant-en-klare lichte vulpasta op acrylbasis

- Voor krimpvrij afwerken van naden (tussen sierprofielen na lijmen, tussen wand en profiel, tussen wanden onderling en tussen wand en plafond), scheuren en oneffenheden in profielen of binnenmuren
- Snel overschilderbaar (na 15min.)
- Kraakt niet

Colle d'installation ultra forte pour surfaces poreuses et applications intérieures

- Colle forte à base d'eau et d'acrylique
- Joint longue durée entre les moulures et le mur et/ou le plafond
- Retirez à l'aide d'une éponge ou d'un chiffon humide
- Doit être conservé à l'abri du gel
- Peut être peinte après séchage (min. 24h)

Colle au MS polymère extra forte pour constructions nouvelles, surfaces non poreuses (carrelage, verre, etc...), environnements humides et revêtements muraux 3D

- Enlevez à l'aide d'une solution savonneuse
- Peut être peinte après séchage (min. 24h)

Colle blanche à base de polymères pour les joints entre les profils

- Appliquez généreusement notre DecoFix Ultra entre chaque joint.
- Pressez fermement les profilés l'un contre l'autre jusqu'à ce que l'adhésif sorte légèrement. Veillez à ne pas faire sortir toute la colle du joint.
- Maintenir un petit espace (entre 0 et 0,2 mm). Utiliser un couteau de peintre pour enlever l'excès de colle.
- Utiliser du FL300 DecoFiller si nécessaire et finir avec du papier de verre.
- Peut être peint après 24 heures.

Enduit léger prêt à l'emploi à base d'acrylique

- Pour une finition irrécusable de joints (entre profils décoratifs après adhésion, entre murs et profils, entre mur et plafond et murs entre eux), fissures, trous et irrégularités dans les profils ou les murs
- Peut être recouvert rapidement (après 15 min.)
- Ne se fissure pas

Extra starker Montagekleber auf saugenden Untergründen und für den Innenbereich

- Starker, wasserbasierter Acrylkleber
- Langhaltende Verbindung zwischen Profilen und Wand und/oder Decke
- Mit leicht feuchtem Schwamm oder Tuch entfernen
- Frostfrei lagern
- Anstrichverträglich nach Aushärtung (min. 24 St.)

Besonders starker MS-Polymerkleber für Neubauten, auf nicht porösem (Fliesen, Glas, ...) Untergrund, Feuchträumen und für 3D Wandvertäfelung

- Mit Seifenlösung entfernen
- Anstrichverträglich nach Aushärtung (min. 24 St.)

Weißer Klebstoff auf Polymerbasis für Nahtverbindungen zwischen den Profilen.

- Verwenden Sie ausreichend DecoFix Ultra in jeder Naht.
- Drücken Sie die Profile zusammen, bis der Kleber leicht austritt.
- Achten Sie darauf, nicht den gesamten Kleber aus der Fuge zu drücken.
- Behalten Sie einen kleinen Spalt bei (zwischen 0 und 0,2 mm).
- Verwenden Sie ein Malermesser, um überschüssigen Kleber zu entfernen.
- Bei Bedarf FL300 DecoFiller verwenden und mit Schleifpapier nacharbeiten.
- Nach mind. 24 Stunden überstreichbar.

Gebrauchsfertige Leichtspachtelmasse auf Acrylbasis

- Zur schrumpffreien Endbearbeitung von Fugen zwischen Dekoprofilen nach der Montage. Kann ebenfalls für das
- Verfüllen der Fugen bzw. Lücken zwischen dem Profil und dem Untergrund auf dem es montiert wurde verwendet werden. Beschädigungen an Wand oder Profil können mit dem Füllstoff nachgearbeitet werden.
- Schnell überstreichbar (nach 15 min.)
- Reißt nicht

Adhesivo superfuerte para soportes porosos y aplicaciones en el interior

- Fuerte, cola acrílica con base de agua
- Gran adherencia del producto en techos o paredes
- Eliminar con una esponja o paño húmedo
- Debe guardarse en un ambiente seco
- Pintable después de endurecimiento (min. 24 horas)

Adhesivo MS polímero extra fuerte para construcciones nuevas, superficies no porosas (cerámica, vidrio, ...), lugares húmedos y revestimientos de pared 3D.

- Eliminar con agua y jabón
- Pintable después de endurecimiento (min. 24 horas)

Adhesivo blanco a base de polímeros para juntas entre perfiles

- Aplica una cantidad suficiente de DecoFix Ultra para cada junta en el lado del perfil ya instalado.
- Presionar firmemente los perfiles hasta que el adhesivo salga ligeramente. Tener cuidado de no empujar todo el adhesivo fuera de la junta.
- Mantener una pequeña separación (entre 0 y 0,2 mm). Utilizar una espátula de pintor para eliminar el exceso de adhesivo.
- Aplicar FL300 DecoFiller en la unión y repasa con papel de lija.
- Se puede pintar después de 24 horas

Masilla ligera lista para usar en base acrílica

- Especial para un buen acabado final de juntas, indicada también para transiciones de los perfiles con las paredes y/o techos. Ideal para sellar pequeñas grietas e irregularidades que nos podemos encontrar en las instalaciones
- Se puede lijar y pintar fácilmente, pasados 15 min. de su aplicación
- No merma, ni fisura

## Tools

TOEBEHOREN  
ACCESSOIRES  
ZUBEHÖR  
ACCESORIOS



FB15

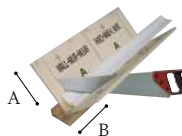

FB300  
A: 29,7 cm | B: 29,1cm

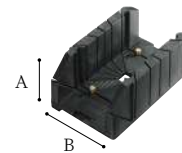

FB13  
A: 12,5 cm | B: 15,5 cm



A38

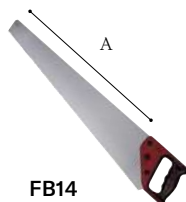

FB14  
A: 60 cm

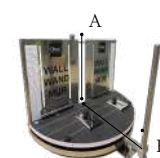

FB10  
A: 27,5 cm | B: 22 cm

# Flexible products

08

FLEXIBELE PRODUCTEN  
PRODUITS FLEXIBLES  
FLEXIBLE PRODUKTE  
PRODUCTOS FLEXIBLES

You may expect walls to be straight by nature. But we invite you to imagine a flowing interior. Many of our solutions are flexible, following or effectively suggesting a curve in a wall. As far as we're concerned, a rounded corner should never be out of the question.

**NL —**

Misschien verwacht u dat muren recht zijn, dat is tenslotte wat we vaak zien. Maar wat als u zich laat leiden door de stroming van een interieur dat speelt met lijnen en rondingen? Onze ontwerpen buigen en weven, ze suggereren de elegantie van een curve. Want voor ons is een afgeronde hoek altijd een optie.

**FR —**

On peut s'attendre à ce que les murs soient droits par nature. Mais nous vous invitons à imaginer un intérieur fluide. Nombre de nos solutions sont flexibles, suivant ou suggérant efficacement la courbe d'un mur. Car pour nous, un coin arrondi ne devrait jamais être exclu.

**DE —**

Sie erwarten vielleicht, dass Wände von Natur aus gerade sind. Wir laden Sie jedoch ein, sich ein fließendes Interieur vorzustellen. Viele unserer Lösungen sind flexibel und folgen einer Kurve in einer Wand oder deuten sie effektiv an. Denn für uns sollte eine abgerundete Ecke niemals unmöglich sein.

**ES —**

Es común esperar que las paredes sean rectas por naturaleza. Pero te invitamos a imaginar un interior orgánico. Muchas de nuestras soluciones son flexibles, siguiendo o sugiriendo una curva en la pared. Porque para nosotros, una esquina redondeada nunca está de más.

# Overview radius of bending

OVERZICHT BUIGRADIUS  
 APERÇU DU RAYON DE CINTRAGE  
 ÜBERSICHT BIEGERADIUS  
 RADIOS MÍNIMOS DE CURVATURA

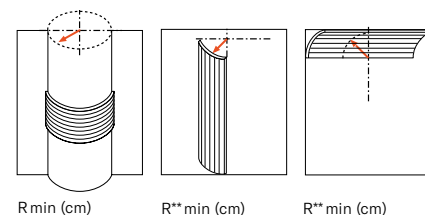
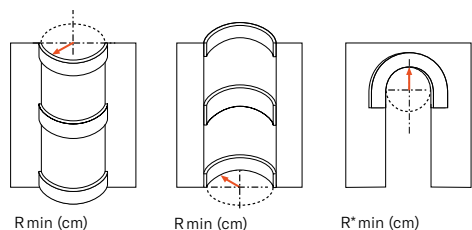

Flex Radius	R min (cm)	R* min (cm)	Flex Radius	R min (cm)	R* min (cm)	Flex Radius	R min (cm)	R* min (cm)	Flex Radius	R min (cm)	R* min (cm)	Flex Radius	R min (cm)	R** min (cm)
C211F	250		CX100F	200		S425	20		P3020F	50	180	W108F	30	40
C213F	280		CX106F	360		SX104F	40		P4020F	40	200	W109F	30	40
C215F	160		CX109F	160		SX105F	30		P4025F	70		W110F	30	40
C217F	380		CX110F	180		SX118F	40		P5021F	20	70	W111F	30	40
C220F	400		CX123F	280		SX137F	40		P7070F	30	230	W114F	30	40
C230F	150		CX124F	160		SX138F	40		P8020F	40	130	W116F	30	40
C240F	270		CX127F	240		SX155F	30		P8030F	20	70	W119F	30	40
C250F	70		CX188F	110		SX157F	35	260	P8040F	30		W214F	30	40
C321F	140		CX189F	90		SX162F	20	80	P8050F	80	200			
C333F	300		CX190F	30	130	SX163F	35		P9010F	40	310	WX205F	30	40
C334F	380		CX199F	200		SX165F	40		P9050F	20	60	WX210F	30	40
C339F	380					SX172F	35		P9900F	20	250	WX211F	30	40
C341F	400					SX173F	45		P9902F	15		WX213F	30	40
C373F	100					SX180F	45		P9903F	25		WX218F	30	40
C901F	600					SX182F	35	100	P9904F	10	35			
C902F	600					SX183F	40		P9905F	15				
						SX184F	45							
						SX187F	40		PX103F	20	80			
						SX194F	25	80	PX120F	30	110			
						SX195F	30		PX144F	20	220			
						SX207F	40		PX175F	30	80			
									PX198F	70				
									PX201F	30	80			
									PX202F	60	150			
									PX209F	20	70			

R min (cm)

R\* min (cm)

R min (cm)

R\*\* min (cm)



SX180F | SX180



PX103F | PX103A | PX103 | C338B



P9010F | P9010



W110F | W110



<sup>1</sup> W108F p.98

# Index

## C

C200	69
C201	73
C211   C211F	40, 41, 42, 50, 51, 70
C212	73
C213   C213F	69
C215   C215F	69
C216	69
C217   C217F	69
C219	73
C220   C220F	69
C230   C230F	69
C240   C240F	76
C250   C250F	76
C260	76
C301	69
C303	73
C304	73
C305	40, 41, 42, 50, 51, 70
C305 + C211	70
C305 + C213	70
C307	70
C307 + C307A	70
C307A	40, 41, 42, 50, 51, 70
C321   C321F	74
C322	69
C323	69, 142
C324	142
C325	67
C326	67
C327	67
C328 <small>NEW</small>	69
C331	73
C332	34, 35, 36, 54, 74, 83
C333   C333F	73
C334   C334F	73
C336	68
C338	68
C338A	68
C338B	68
C339   C339F	74
C340	74, 83
C341   C341F	66, 83
C342	66, 83
C343	46, 47, 52, 66, 83, 121, 148
C344	66
C352	143
C353	80
C354	80
C355	80
C356	80
C357	143
C360	80
C361	153, 154
C362	154
C371	154
C373   C373F	152
C374	152
C380	145

C381	145
C382	145
C383	145
C390	27, 79, 83, 89, 147, 150
C391	25, 26, 30, 79, 83, 147
C392	27, 59, 79
C393	25, 26, 30, 79, 86, 146
C394	30, 79, 83, 147, 153
C395	79, 83, 147
C396	79, 83, 147
C400	80
C422	70
C602	80
C900	73, 143
C901   C901F	73, 143
C902   C902F	73
C990	14, 15, 76, 77
C990 + 2x P9900	77
C990 + P9900	77
C991	31, 77, 81, 83, 132, 153, 154
C991 + 2xP9900	31
C992 <small>NEW</small>	77
C993 <small>NEW</small>	77
C994 <small>NEW</small>	77
CB500	92
CB500N	92
CB501	92
CB501N	92
CB502	92
CB502N	92
CB503	93
CB503N	93
CB510	92
CB510N	92
CB511	92
CB511N	92
CB512	92
CB512N	92
CB520	92
CB520N	92
CB521	92
CB521N	92
CB522	92
CB522N	92
CB523	92
CB523N	92
CB524	93
CB524N	93
CB525	92
CB525N	92
CX100   CX100F	86
CX106   CX106F	86
CX107	87
CX108	87
CX109   CX109F	88
CX110   CX110F	87
CX111	87
CX112	87
CX115	88
CX123   CX123F	86
CX124   CX124F	86
CX126	88
CX127   CX127F	86

CX129	87
CX132	88, 120
CX133	88, 120
CX134	137
CX141	88
CX148	88
CX160	54, 91
CX161	91
CX176	88
CX177	87
CX188   CX188F	14, 15, 30, 31, 76, 150
CX189   CX189F	150
CX190   CX190F	18, 19, 25, 26, 28, 29, 89, 99, 103, 120, 122, 124, 136, 150
CX192	88, 90
CX196	84, 89, 150
CX197	84, 89, 136, 150
CX199   CX199F	86
CX203   CX203F	86
CX215-2600 <small>NEW</small>	84, 88, 148
CX216-2600 <small>NEW</small>	84, 88, 148
CX217-2600 <small>NEW</small>	84, 88, 148

## D

D170	163
D200	162
D210	162
D310	162
D330LR	41, 52, 107, 162
D340	162
D400	163
D401	163
D402	163
D503	163
D504	163
D507	163
DX119-2600 <small>NEW</small>	134, 162
DX121-2600 <small>NEW</small>	134, 162
DX157-2600 <small>NEW</small>	162
DX163-2600 <small>NEW</small>	162
DX170-2600 <small>NEW</small>	41, 52, 107, 116, 134, 162
DX174-2600 <small>NEW</small>   DX174F	134
DX180-2600 <small>NEW</small>	123, 162
DX187-2600 <small>NEW</small>	123, 162

## F

F30	111
-----	-----

## K

K200	165
K201	165
K202	165
K250	165
K251	165
K254	165

K1001 164  
 K1002 164  
 K1101 164  
 K1102 164  
 K1111 164  
 K1112 164  
 K1121 164  
 K1122 164  
 K1131 164  
 K1132 164  
 K1151 164  
 K1152 164

## P

P20 139  
 P101A 139  
 P801C 139  
 P1020 129  
 P3020 | P3020F 39, 129, 138  
 P3020A 39, 139  
 P3070 130  
 P3071 130  
 P4000 128  
 P4010 128  
 P4020 | P4020F 40, 41, 42, 46, 52, 53, 128, 134  
 P4020A 139  
 P4025 | P4025F 117, 128  
 P5021 | P5021F 130  
 P6020 129  
 P7020 129  
 P7030 129  
 P7070 | P7070F 27, 118, 123, 130  
 P8020 | P8020F 46, 52, 53, 66, 67, 75, 86, 121, 128, 134  
 P8030 | P8030F 38, 39, 51, 54, 67, 71, 86, 90, 128  
 P8030C 139  
 P8030D 139  
 P8040 | P8040F 128  
 P8050 | P8050F 39, 50, 128, 138  
 P8060 130  
 P9010 | P9010F 48, 49, 116, 128, 131  
 P9020 128  
 P9040 128  
 P9050 | P9050F 48, 49, 116, 130  
 P9900 | P9900F 24, 130  
 P9901 130  
 P9902 | P9902F NEW 132  
 P9903 | P9903F NEW 108, 132  
 P9904F NEW 132  
 P9905 | P9905F NEW 132  
 PX103 | PX103F 93, 114, 135  
 PX103A 139  
 PX113 135  
 PX116 135  
 PX117 135  
 PX120 | PX120F 40, 41, 42, 135, 153  
 PX120A + PX120 139  
 PX144 | PX144F 135  
 PX147 136

PX169 136  
 PX175 | PX175F 38, 39, 51, 71, 125, 135  
 PX198 | PX198F 89, 103, 120, 122, 136  
 PX201 | PX201F 135  
 PX202 | PX202F 135  
 PX209 | PX209F 14, 15, 36, 99, 100, 101, 137, 142

## R

R07 160  
 R08 160  
 R09 160  
 R10 158  
 R11 158  
 R12 158  
 R13 159  
 R14 159  
 R17 159  
 R18 159  
 R22 159  
 R23 159  
 R24 159  
 R27 159  
 R31 159  
 R40 160  
 R52 159  
 R64 159  
 R73 159  
 R76 160  
 R77 160

## S

S425 | S425F NEW 69, 123, 132, 133  
 SX104 | SX104F 119  
 SX105 | SX105F 116  
 SX118 | SX118F 75, 115, 142  
 SX125 120  
 SX137 | SX137F 117  
 SX138 | SX138F 34, 36, 37, 107, 117  
 SX155 | SX155F 116, 131  
 SX156 119  
 SX157 | SX157F 91, 115, 122, 137, 149  
 SX159 120, 122, 135  
 SX162 | SX162F 91, 115, 122  
 SX163 | SX163F 91, 115, 122, 137  
 SX165 | SX165F 115  
 SX168 122, 137  
 SX171 115, 125  
 SX172 | SX172F 120  
 SX173 | SX173F 115  
 SX179 120, 150  
 SX180 | SX180F 24, 27, 30, 118, 123, 145, 146  
 SX181 108, 118, 123  
 SX182 | SX182F 14, 17, 91, 97, 101, 115, 122, 123, 137  
 SX183 | SX183F 91, 115, 123, 137  
 SX184 | SX184F 91, 115, 123  
 SX185 115, 125  
 SX186 115, 125

SX187 | SX187F 118, 123  
 SX191 51, 52, 53, 67, 71, 119  
 SX193 117  
 SX194 | SX194F 18, 19, 24, 91, 120, 122, 137  
 SX195 | SX195F 116  
 SX206 46, 117, 134  
 SX207 | SX207F 26, 97, 122, 137  
 SX212 123, 137

## W

W100 110  
 W101 110  
 W105 110  
 W106 110  
 W107 110  
 W108 | W108F 98, 100, 103, 173  
 W108-2600 98  
 W109 | W109F 48, 49, 100, 121, 142  
 W109-2600 100  
 W110 | W110F 20, 21, 36, 98  
 W110-2600 98  
 W111 | W111F 25, 89, 97, 103  
 W111-2600 103  
 W112 105  
 W113 105  
 W114 | W114F 18, 19, 100  
 W114-2600 100  
 W115 16, 17, 104, 151  
 W116 | W116F 25, 89, 103  
 W116-2600 NEW 103  
 W119 | W119F 25, 89, 103  
 W119-2600 NEW 103  
 W120 106, 117, 119  
 W121 106, 117, 119  
 W122 106, 117  
 W123 106, 117  
 W124 109  
 W125 NEW 109  
 W125A NEW 109  
 W126 NEW 109  
 W130 105  
 W212 100, 142  
 W213 98  
 W214 | W214F 34, 35, 36, 37, 98  
 W215 34, 36, 37, 98  
 W216 26, 104  
 W217 14, 17, 101  
 W218 14, 17, 101  
 W219 104  
 WX204 97  
 WX204-2600 97  
 WX205 | WX205F 97  
 WX205-2600 97  
 WX210 | WX210F 36, 97, 99  
 WX211 | WX211F 36, 97, 99  
 WX211-2600 97  
 WX213 | WX213F NEW 97  
 WX213-2600 NEW 97  
 WX218 | WX218F NEW 97  
 WX218-2600 NEW 97

# Colophon

## Concept

Base Design  
zworm.studio

## Graphic design

Beau De Maeschalck

## Special thanks to

BLCN Design	blcn-design.com	8
The HUB Ghent	thehub.be	18–19
The HUB Brussels	thehub.be	145
The Room Studio	theroom-studio.com	12, 15, 56
Maison Numéro 20	maisonnumero20.fr	20–21
Atelier DAAA	atelierdaaa.com	28–29, 90, 124
Marie-Emilie Geerinckx	marieemiliegeerinckx.be	30–31, 146
Aboco	aboco.be	38–39, 138
Geoffroy Van Hulle	geoffroyvanhulle.com	40–41, 42–43, 54–55, 76, 84
Van Damme - Vandeputte architects	vandammevandeputte.com	50–51, 71, 126, 129
LOFT4C	loft4c.be	52–53
Anthony Boelaert	anthonyboelaert.be	68
Interieurprojects	interieurprojects.com	81
Sur Mesure Interieur	surmesure-interieur.be	75, 82
Sofie de Kruijff	thomestyleclub.com	100
Atelier En Aparté	atelierenaparté.com	108
Blume Studio	blumestudio.es	109
Madrid Forest	madridforest.com	109
Hotel Du Parc Oostende	hotelduparc.be	112
D-ZAJN	d-zajn.be	112
Hotel Astoria De Haan	hotelastoria.be	117
Roelfien Vos	roelfienvos.com	108, 133, 153, 155
Perfect Living	perfectliving.be	158
Alina Vilhjálmisdóttir		161
Eichholtz	eichholtz.com	165
Belén Imaz	belenimaz.com	109
Cafeine	cafeine.be	18–19, 28–29, 50–51, 71, 90, 117, 124, 126, 129
Damon De Backer	damondebacker.com	43
Didier Delmas	didierdelmas.com	20–21
DVO Photographic	dvo-photographic.be	81
Hannelore Veelaert	hanneloreveelaert.com	8, 38–39, 112, 138
Lotte van Uittert	lottevanuittert.com	100
Rebecka Oftedal		108
Space Content Studio	spacecontent.studio	85, 149
Stephanie Mathias	stephaniemathias.be	75, 82
Tijs Vervecken	tijsvervecken.com	30–31, 40–41, 42–43, 52–53, 54–55, 76, 84, 145, 146
Verne	verne.be	
Willem Van Puyenbroeck	willemvanpuyenbroeck.com	158
Maud Lebossé Testud		172

Guarantee terms and conditions apply if provided installation instructions have been followed to the letter. Fire retardant standards. In many interiors and projects strict fire regulations are imposed. Therefore, ORAC has implemented a number of solutions depending on the country and its regulations. Please contact us for more information. The information in this catalogue is without engagement. Changes and discrepancies in sizes or/and shapes against those stated in the catalogue can occur. This catalogue and the design embodied within are protected by copyright law and international treaties. Unauthorized reproduction of the catalogue, any portion of it or the reproduction of the designs embodied therein may result in severe civil and criminal penalties and will be prosecuted to the maximum.

Further legal information can be found on: [www.oracdecor.com/nl/disclaimer](http://www.oracdecor.com/nl/disclaimer).



This catalogue is printed on FSC-certified paper.

ORAC Headquarters | nv ORAC sa

Biekorfstraat 32  
8400 Ostend, Belgium  
T +32 59 80 32 52  
info@oracdecor.com

ORAC Benelux

Biekorfstraat 32  
8400 Ostend, Belgium  
NL: T +31 852 08 40 59  
BeLux: T +32 59 79 02 82  
benelux@oracdecor.com

ORAC Bŭlgariya

T +40 (31) 630 06 19  
bulgaria@oracdecor.com

ORAC Deutschland

BoltensternstraÙe 159A  
50735 KŃln, Deutschland  
T +49 221 747 499 39  
deutschland@oracdecor.com

ORAC EspaÙa

C/ del RossellŃ, 229  
08008 Barcelona, EspaÙa  
T +34 938 56 49 00  
spain@oracdecor.com

ORAC Eesti

T +372 58 55 8668  
eesti@oracdecor.com

ORAC Export

T +32 59 79 02 83  
export.cs@oracdecor.com

ORAC France

13 Rue SŃguier  
75006 Paris, France  
T +33 188803631  
france@oracdecor.com

ORAC Ireland

T +35 381 8000 280  
ireland@oracdecor.com

ORAC Italia srl

Corso Giacomo Matteotti, 5/H  
23900 Lecco (LC), Italia  
T +39 0341 362062  
italia@oracdecor.com

ORAC Latvija

T +371 6838 8858  
latvija@oracdecor.com

ORAC Lietuva

T +370 6999 0006  
lietuva@oracdecor.com

ORAC Ŗsterreich

T +43 662 23 49 27  
oesterreich@oracdecor.com

ORAC Polska

ul. Pomorska 106A  
91-402 ŁŃdŹ, Polska  
T +48 42 203 60 56  
polska@oracdecor.com

ORAC RumŃniya

Blvd. I.C. Bratianu nr. 10, floor 1, district 3  
Bucharest, cod 030174, Romania  
T +40 31 630 06 19  
romania@oracdecor.com

ORAC Schweiz

T 0800 562 118  
switzerland@oracdecor.com

ORAC Slovakia s.r.o.

Kpt. Nalepku 6  
08271 Lipany, Slovakia  
T +421 232 784 952  
slovakia@oracdecor.com

ORAC UK ltd.

The Courtyard  
30 Worthing Road  
Horsham RH12 1SL  
T +44 1403 240 102  
uk@oracdecor.com

# ORFAC

